

TECHNICAL MANUAL
 DIRECT SUPPORT AND
 GENERAL SUPPORT
 MAINTENANCE MANUAL INCLUDING
 REPAIR PARTS AND
 SPECIAL TOOLS LIST

VOLUME I - TROUBLESHOOTING

VOLUME II - MAINTENANCE

MOUNT, TELESCOPE, M 114
 (1240-00-676-2176)

MAY 1985

VOLUME I TROUBLESHOOTING	CHAPTER 1		
	INTRODUCTION	1-1	
	CHAPTER 2		
	CHECKOUT PROCEDURE	2-1	
	CHAPTER 3		
	FAULT SYMPTOM INDEX	3-1	
	CHAPTER 4		
	FAULT ISOLATION PROCEDURES	4-1	

VOLUME II MAINTENANCE	CHAPTER 1		
	INTRODUCTION	1-1	
	CHAPTER 2		
	GENERAL MAINTENANCE INFORMATION	2-1	
	CHAPTER 3		
	INSPECTION UPON RECEIPT	3-1	
	CHAPTER 4		
	MAINTENANCE PROCEDURES	4-1	
	CHAPTER 5		
	FINAL INSPECTION	5-1	
	CHAPTER 6		
	PACKAGING	6-1	
	APPENDIX A		
	EXPENDABLE SUPPLIES AND MATERIALS LIST	A-1	
	APPENDIX B		
	MAINTENANCE TASK INDEX	B-1	
	APPENDIX C		
	FABRICATED TOOLS	C-1	
	APPENDIX D		
	REPAIR PARTS AND SPECIAL TOOLS LIST	D-1	

CHANGE

No. 1

HEADQUARTERS
DEPARTMENT OF THE ARMY
Washington, DC 30 January 1987

DIRECT SUPPORT AND
GENERAL SUPPORT
MAINTENANCE MANUAL INCLUDING
REPAIR PARTS AND SPECIAL
TOOLS LIST

VOLUME I - TROUBLESHOOTING
VOLUME II - MAINTENANCE

MOUNT, TELESCOPE, M114
(1240-00-676-2176)

TM 9-1240-385-34&P, 2 May 1985, is changed as follows:

1. Remove old pages and insert new pages as indicated below.
2. New or changed material is indicated by a vertical bar in the margin of the page.
3. New or changed illustrations are indicated by a miniature pointing hand highlighting the change.

**Volume I
Remove Pages**

iii and iv

**Volume II
Remove Pages**

5-1 and 5-2
A-1 and A-2

**Volume I
Insert Pages**

iii and iv

**Volume II
Insert Pages**

5-1 and 5-2
A-1 and A-2

File this sheet in the back of the publication for reference purposes.

WARNING

Two repairmen are needed to install telescope mount. If telescope mount falls, equipment damage and injury to personnel may result.

Technical Manual
No. 9-1240-285-34&P

HEADQUARTERS,
DEPARTMENT OF THE ARMY
Washington, D. C., 2 May 1985

TECHNICAL MANUAL
DIRECT SUPPORT AND
GENERAL SUPPORT
MAINTENANCE MANUAL INCLUDING
REPAIR PARTS AND SPECIAL
TOOLS LIST

MOUNT, TELESCOPE, M114
(1240-00-676-2176)

REPORTING ERRORS AND RECOMMENDING IMPROVEMENTS

You can help improve this manual. If you find any mistakes or if you know of a way to improve the procedures, please let us know.

Mail your letter, DA Form 2028 (Recommended Changes to Publications and Blank Forms), or DA Form 2028-2 located in the back of this manual directly to:

Commander
US Army Armament , Munitions and Chemical Command
ATTN: AMSMC-MAS
Rock Island, IL 61299-6000

A reply will be furnished to you.

*This manual supersedes the DS/GS portion of TM 9-1240-285-35, July 1960 and TM 9-1240-285-34P, March 1971.

TABLE OF CONTENTS

	Paragraph	Page
HOW TO USE THIS MANUAL		vi
VOLUME I TROUBLESHOOTING		
CHAPTER 1. INTRODUCTION.....		1-1
Scope	1-1	1-1
Organization	1-2	1-1
How to Troubleshoot	1-3	1-2
Sample Fault Isolation Procedure	1-4	1-4
CHAPTER 2. CHECKOUT PROCEDURE.....		2-1
Scope	2-1	2-1
Checkout	2-2	2-1
CHAPTER 3. FAULT SYMPTOM INDEX.....		3-1
CHAPTER 4. FAULT ISOLATION PROCEDURES.....		4-1
Scope	4-1	4-1
Deflection Locking Mechanism Does Not Hold		
Deflection Boresight Adjusting Mechanism	4-2	4-1
Elevation Locking Mechanism Does Not Hold		
Elevation Boresight Adjusting Mechanism	4-3	4-4
Deflection Boresight Adjusting Mechanism Does		
Not Turn Freely (with Deflection Lock		
Not Set)	4-4	4-8
Elevation Boresight Adjusting Mechanism Does		
Not Turn Freely (With Elevation Lock		
Not Set)	4-5	4-14
VOLUME II MAINTENANCE		
CHAPTER 1. INTRODUCTION		1-1
Section 1. General		1-1
Scope	1-1	1-1
Organization	1-2	1-1
Section 2. Description and Data		1-2
Description	1-3	1-2
Tabulated Data	1-4	1-4
CHAPTER 2. GENERAL MAINTENANCE INFORMATION		2-1
Section 1. General		2-1
Scope	2-1	2-1

TABLE OF CONTENTS (CONT)

		Paragraph	Page
Section 2.	Reference Documents		2-1
	General Maintenance	2-2	2-1
	Cleaning	2-3	2-1
	Painting	2-4	2-1
	Sealing	2-5	2-1
	Lubrication	2-6	2-1
Section 3.	Safety Procedures		2-1
	General Procedure	2-7	2-1
Section 4.	Special Tools and Test Equipment		2-2
	Tools and Test Equipment	2-8	2-2
CHAPTER 3.	INSPECTION UPON RECEIPT		3-1
	Scope	3-1	3-1
	Inspection Upon Receipt	3-2	3-1
CHAPTER 4.	MAINTENANCE PROCEDURES		4-1
Section 1.	General		4-1
	Scope	4-1	4-1
	List of Telescope Mount Items Contained in This Chapter	4-2	4-1
Section 2.	Decals		4-2
	Decal Removal and Replacement	4-3	4-2
Section 3.	Telescope Mount		4-4
	Telescope Mount Maintenance Procedures Index	4-4	4-4
	Telescope Mount Removal	4-5	4-4
	Telescope Mount Installation	4-6	4-8
Section 4.	Deflection and Elevation Locking Mechanisms		4-12
	Deflection and Elevation Locking Mechanisms Maintenance Procedures Index	4-7	4-12
	Deflection and Elevation Locking Mechanisms Disassembly	4-8	4-12
	Deflection and Elevation Locking Mechanisms Assembly	4-9	4-14
Section 5.	Elevation Boresight Adjusting Mechanism		4-18
	Elevation Boresight Adjusting Mechanism Maintenance Procedures Index	4-10	4-18
	Elevation Boresight Adjusting Mechanism Disassembly	4-11	4-18
	Elevation Boresight Adjusting Mechanism Assembly	4-12	4-22

TABLE OF CONTENTS (CONT)

		Paragraph	Page
Section 6.	Deflection Boresight Adjusting Mechanism		4-26
	Deflection Boresight Adjusting Mechanism Maintenance Procedures Index	4-13	4-26
	Deflection Boresight Adjusting Mechanism Disassembly	4-14	4-26
	Deflection Boresight Adjusting Mechanism Assembly	4-15	4-30
Section 7.	Holder Assembly		4-34
	Holder Assembly Maintenance Procedures Index	4-16	4-34
	Holder Assembly Removal	4-17	4-34
	Holder Assembly Disassembly	4-18	4-36
	Holder Assembly Assembly	4-19	4-38
	Holder Assembly Installation	4-20	4-40
Section 8.	Slide Assembly and Boots		4-42
	Slide Assembly and Boots Maintenance Procedures Index	4-21	4-42
	Slide Assembly and Boots Removal	4-22	4-42
	Slide Assembly and Boots Installation	4-23	4-45
CHAPTER 5.	FINAL INSPECTION		5-1
	Scope	5-1	5-1
	Backlash Check.	5-2	5-1
	Final Inspection	5-3	5-4
CHAPTER 6.	PACKAGING		6-1
	Scope	6-1	6-1
	Packaging of the M114 Telescope Mount	6-2	6-1
APPENDIX A.	EXPENDABLE/DURABLE SUPPLIES AND MATERIALS LIST		A-1
Section 1.	Introduction		A-1
	Scope	A-1	A-1
	Explanation of Columns	A-2	A-1
Section 2.	Expendable/Durable Supplies and Materials		A-2
APPENDIX B.	MAINTENANCE TASK INDEX		B-1
	Scope	B-1	B-1
	Maintenance Task Index	B-2	B-2
APPENDIX C.	FABRICATED TOOL		C-1
	Scope	C-1	C-1
	Spring Wrench	C-2	C-2

TABLE OF CONTENTS (CONT)

	Paragraph	Page	Figure
APPENDIX D. DIRECT SUPPORT AND GENERAL SUPPORT MAINTENANCE REPAIR PARTS AND SPECIAL TOOLS LIST.....		D-1	
Section I. Introduction.....		D-1	
Section II. Repair Parts List		D-7	
Group 00 M114 Telescope mount 8574690		D-9	D-1
00 M114 Telescope mount 8574690		D-11	D-2
0001 Holder assembly 8574694.....		D-11	D-2
0002 Housing assembly 8574691		D-11	D-2
Section III. Special Tools List (not applicable)		D-13	
Section IV. National Stock Number and Part Number Index		D-15	

HOW TO USE THIS MANUAL

This manual has two volumes of maintenance information you will need to repair and service the M114 Telescope Mount.

- Volume I - Troubleshooting
- Volume II- Maintenance

The organization paragraph in each volume tells you what information you can find in each chapter and appendix.

There are four ways to find any maintenance information you need:

- Index on the front cover which tells what information is contained in each chapter
- Table of contents located at the front of the manual which has a complete listing by paragraph number and page number
- Fault Symptom Index (Vol I, Chap 3) which lists the fault symptoms and shows where to look to fix them
- Maintenance task index (Vol II, App. B) which lists major assemblies, subassemblies and paragraph numbers of all maintenance procedures

Before doing any maintenance, you should read and understand HOW TO TROUBLESHOOT on page 1-2. If you do not know the equipment well, you should read the section on description and data (Vol II, Chap 1).

Throughout the manual reference is made to a **Job** Performance Guide 113-091-9000R (JPG 41C) which helps you to develop skills in doing the maintenance tasks.

TECHNICAL MANUAL

DIRECT SUPPORT AND
GENERAL SUPPORT
MAINTENANCE MANUAL INCLUDING
REPAIR PARTS AND SPECIAL
TOOLS LIST (INCLUDING DEPOT
MAINTENANCE REPAIR PARTS)

VOLUME I - TROUBLESHOOTING

MOUNT, TELESCOPE: M114

CHAPTER 1

INTRODUCTION

1-1. SCOPE

This volume contains troubleshooting requirements and procedures for direct support and general support (DS/GS) maintenance of the M114 Telescope Mount. See Volume II for maintenance procedures.

1-2. ORGANIZATION

a. Chapter 2, Checkout Procedure, gives you flow charts to follow to check that the telescope mount is working right.

b. Chapter 3, Fault Symptom Index, lists the fault symptoms and where to look in this manual to fix each one.

c. Chapter 4, Fault Isolation Procedures, shows you step-by-step how to troubleshoot the faults found in Chapter 3.

1-3. HOW TO TROUBLESHOOT

The following steps tell you how to troubleshoot. A diagram of these steps is on page 1-3.

- Ⓐ Do a visual check and list any faults on DA Form 2404 before making repairs. See Vol II, Chap 3 for what to check for.
- Ⓑ If you see any faults that may affect the checkout procedure, fix them now. This does not mean small things like painting scratches.
- Ⓒ Do the checkout procedure in Vol I. Chap 2 from the beginning until you find a fault symptom.
- Ⓓ When a fault symptom is found, go to the chapter noted and follow the maintenance procedure given there. If you already know the fault symptom, look at the fault symptom index in Chapter 3 of this volume. This will also tell you what to do.
- Ⓔ After the fault symptom has been corrected, do the checkout procedure in Chapter 2 again. This is to make sure that all fault symptoms have been corrected.
- Ⓕ If all fault symptoms are now correct, do the remaining maintenance tasks on DA Form 2404.
- Ⓖ Do the final inspection given in Vol II, Chap 5.
- Ⓗ The job is over and the good assembly is sent back to service.
- Ⓘ If all fault symptoms were not corrected after step E, the bad assembly is sent back to the depot for repair.

The sample fault isolation procedure (para 1-4) shows you how to use the flow charts in this volume.

1-3. HOW TO TROUBLESHOOT (CONT)

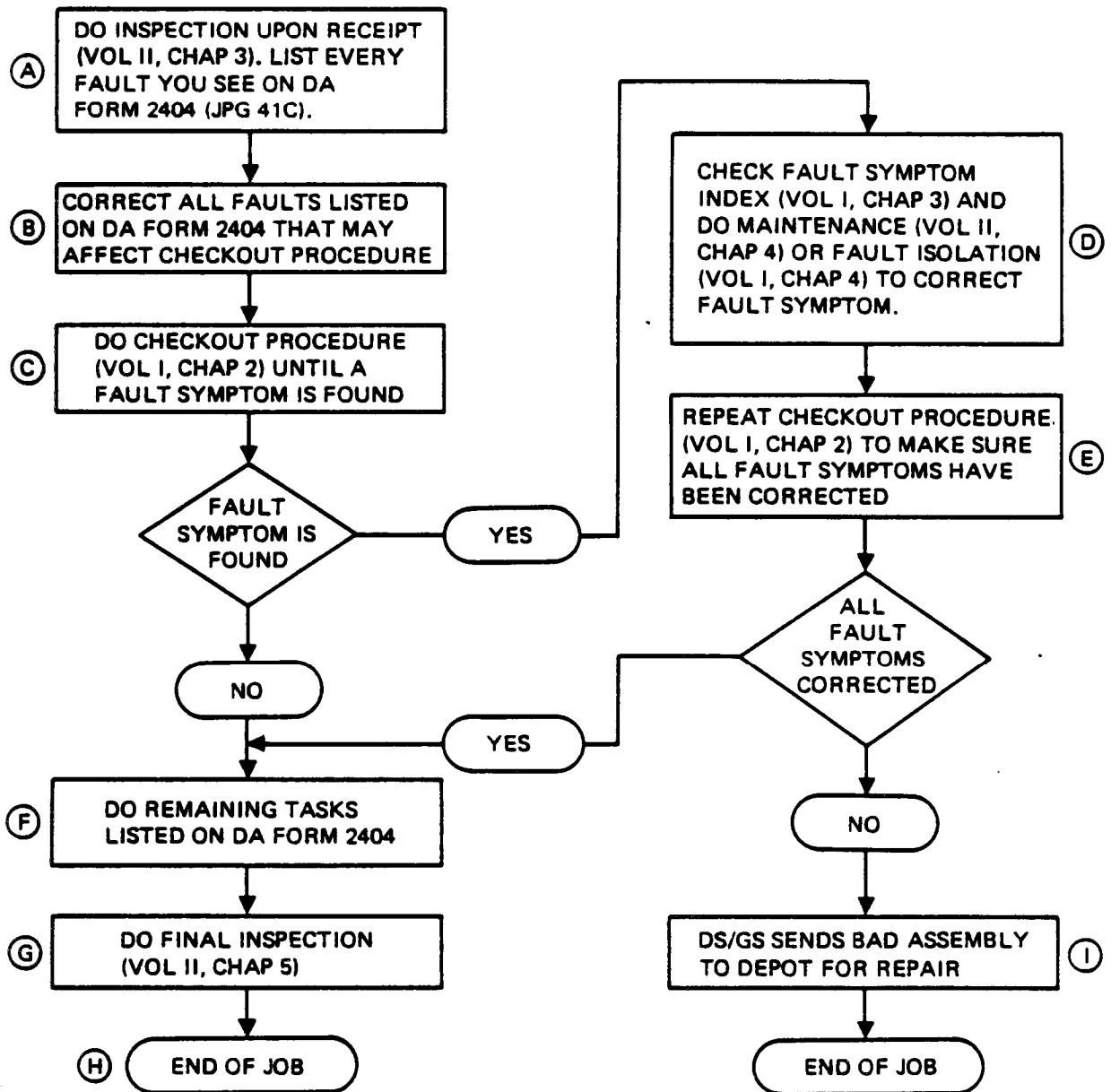

1-4. SAMPLE FAULT ISOLATION PROCEDURE

The sample fault isolation procedure tells you how to use the flow charts in Chapters 2 and 4.

Callouts	Description
<p>Ⓐ</p> <p>Ⓑ</p> <p>Ⓒ</p> <p>Ⓓ</p> <p>Ⓔ</p>	<p>This is the symptom shown in the Fault Symptom Index in Chapter 3.</p> <p>Block number. Tells you the number of the block on the page. Block numbers start over at every page.</p> <p>This is a note. It gives useful information that can help you in doing the procedure. A note will always come just before the step of the procedure that it is about.</p> <p>A warning will be labeled at top of block. Always follow the instruction in this kind of block carefully: If you don't, you may be injured or injure someone else,</p> <p>A caution will also be labeled at top of block. The instructions in this kind of block tell you what to do so you will not damage equipment. Be sure you always follow caution instructions carefully.</p> <p>Index numbers are found in the procedures and the illustration to help you find the connector, switch, knob, etc. The illustration will always be on the same or an opposite page. Remember you will never have to turn the page to find the illustration.</p> <p>The circle is used to send you to another sheet of procedure to keep on troubleshooting. The top number in the circle tells you what sheet to go to. The bottom number tells you what block on that sheet to start with. For example:</p> <p style="text-align: center;">  </p> <p>means that you should go to sheet 3 block 01 to keep on the procedure.</p>

1-4. SAMPLE FAULT ISOLATION PROCEDURE (CONT)

4-3. VIEW IS NOT CLEAR (SHEET 2 OF 3)

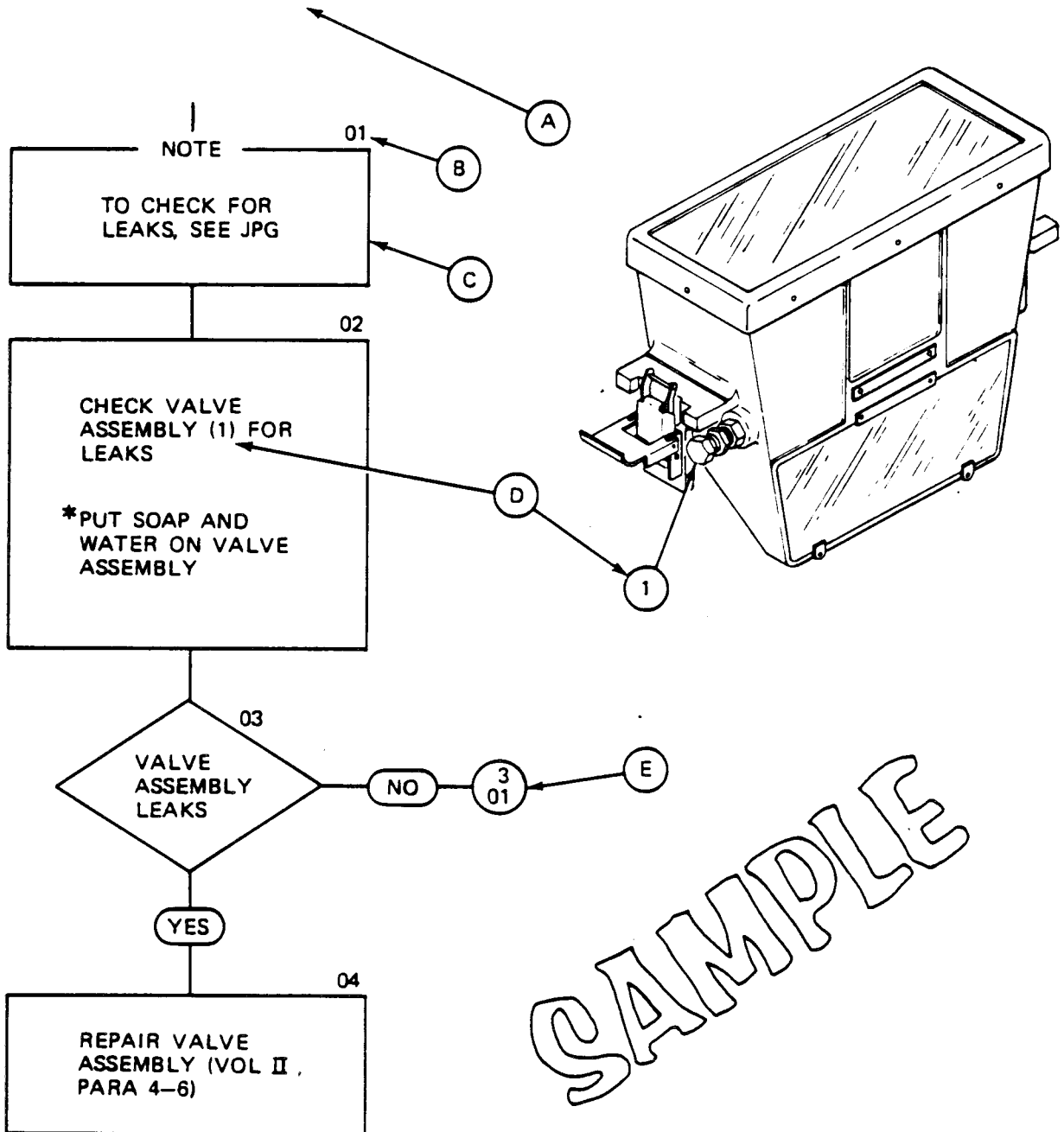

1-4. SAMPLE FAULT ISOLATION PROCEDURE (CONT)

Callouts	Description
<p>ⓕ</p> <p>ⓖ</p> <p>ⓗ</p>	<p>This tells you where you came from. For example, 2.03 means you came from sheet 2, block 03.</p> <p>The top part of the box tells you what to do. The bottom part tells you how to do it. After you become more skilled at troubleshooting and know more about the equipment, you may find that you only need to read the top part of the box.</p> <p>This diamond shaped box is called a decision point. It asks you to answer a YES or NO question, after doing the what-to-do statement. If the answer is YES, you should go down the "YES" branch. If the answer is NO, you should go down the "NO" branch.</p>

1-4. SAMPLE FAULT ISOLATION PROCEDURE (CONT)

4-3. VIEW IS NOT CLEAR (SHEET 3 OF 3)

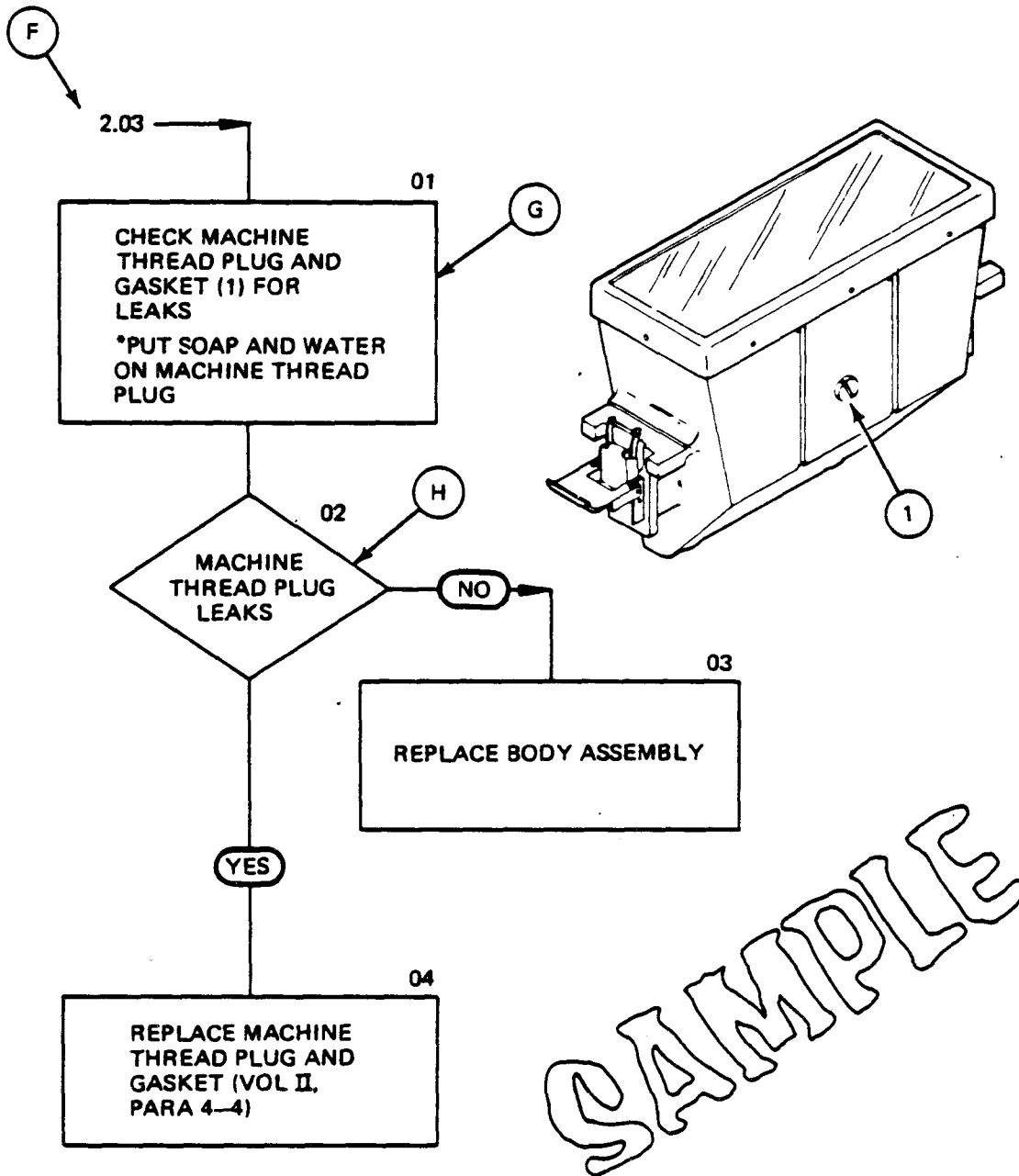

CHAPTER 2

CHECKOUT PROCEDURE

2-1. SCOPE

Checkout of the M114 Telescope Mount is done by using the flow chart procedures in this chapter. You must do the checkout procedure from the beginning until a fault symptom is found. When it is, go to the fault symptom index in Chapter 3. After you have corrected the fault, start at the beginning again and do the checkout procedure until the telescope mount is working correctly.

2-2. CHECKOUT (SHEET 1 OF 6)

PERSONNEL: One

EQUIPMENT CONDITION: Telescope mount on work bench

PRELIMINARY PROCEDURES: Do inspection upon receipt (Vol II, para 3-2)

2-2. CHECKOUT SHEET 2 OF 6

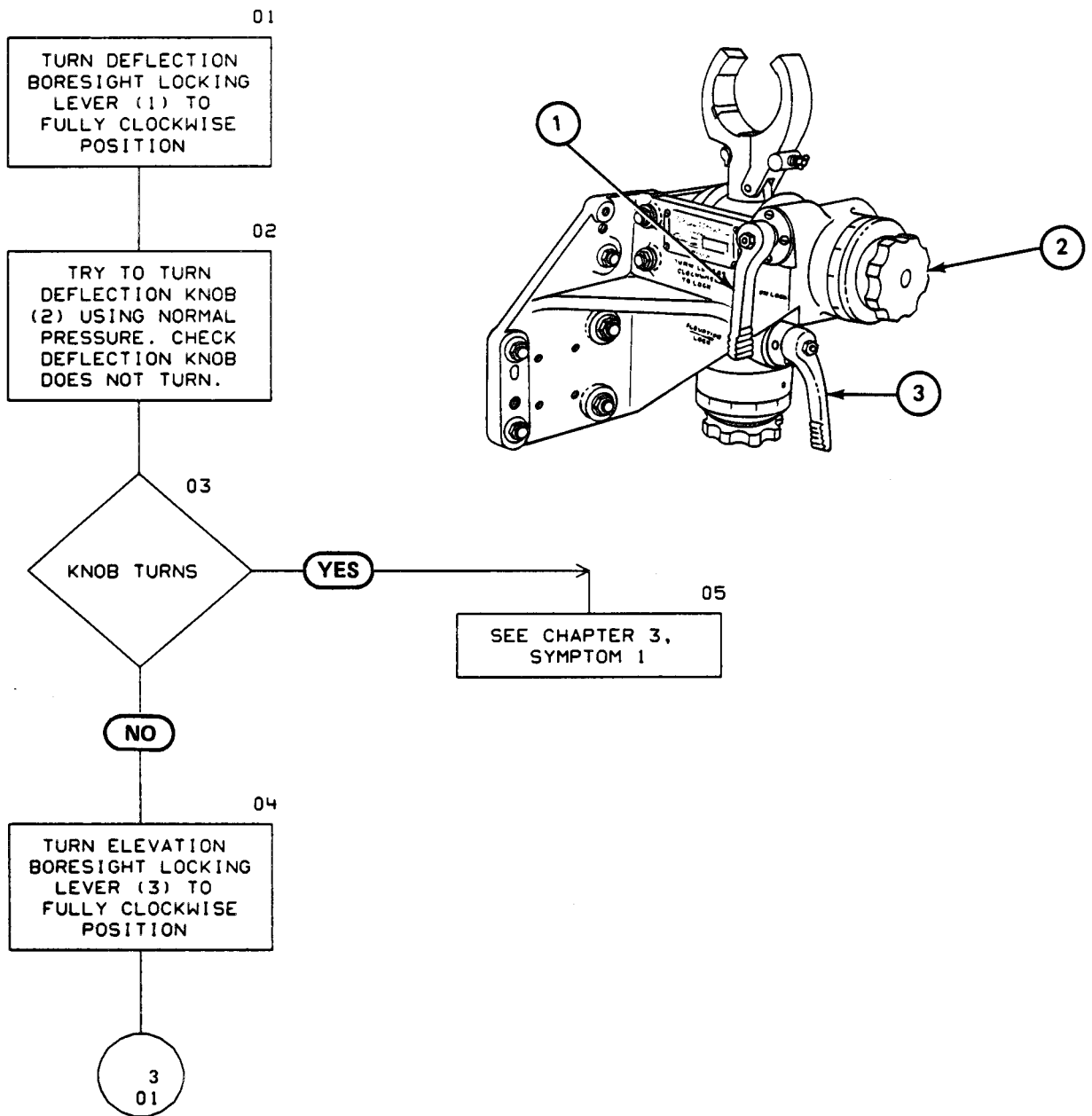

2-2. CHECKOUT (SHEET 3 OF 6)

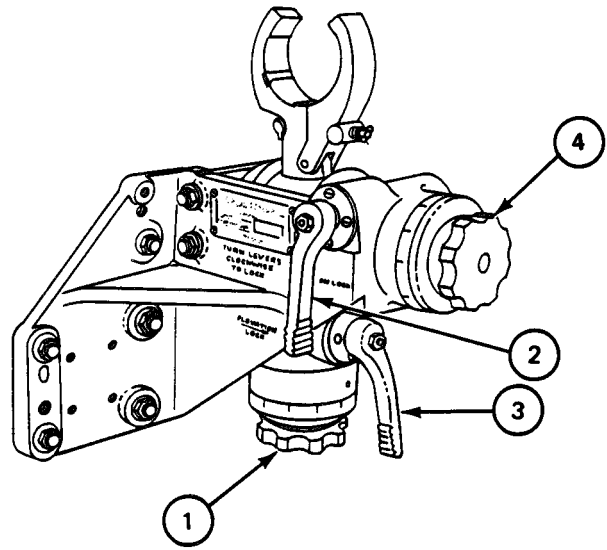
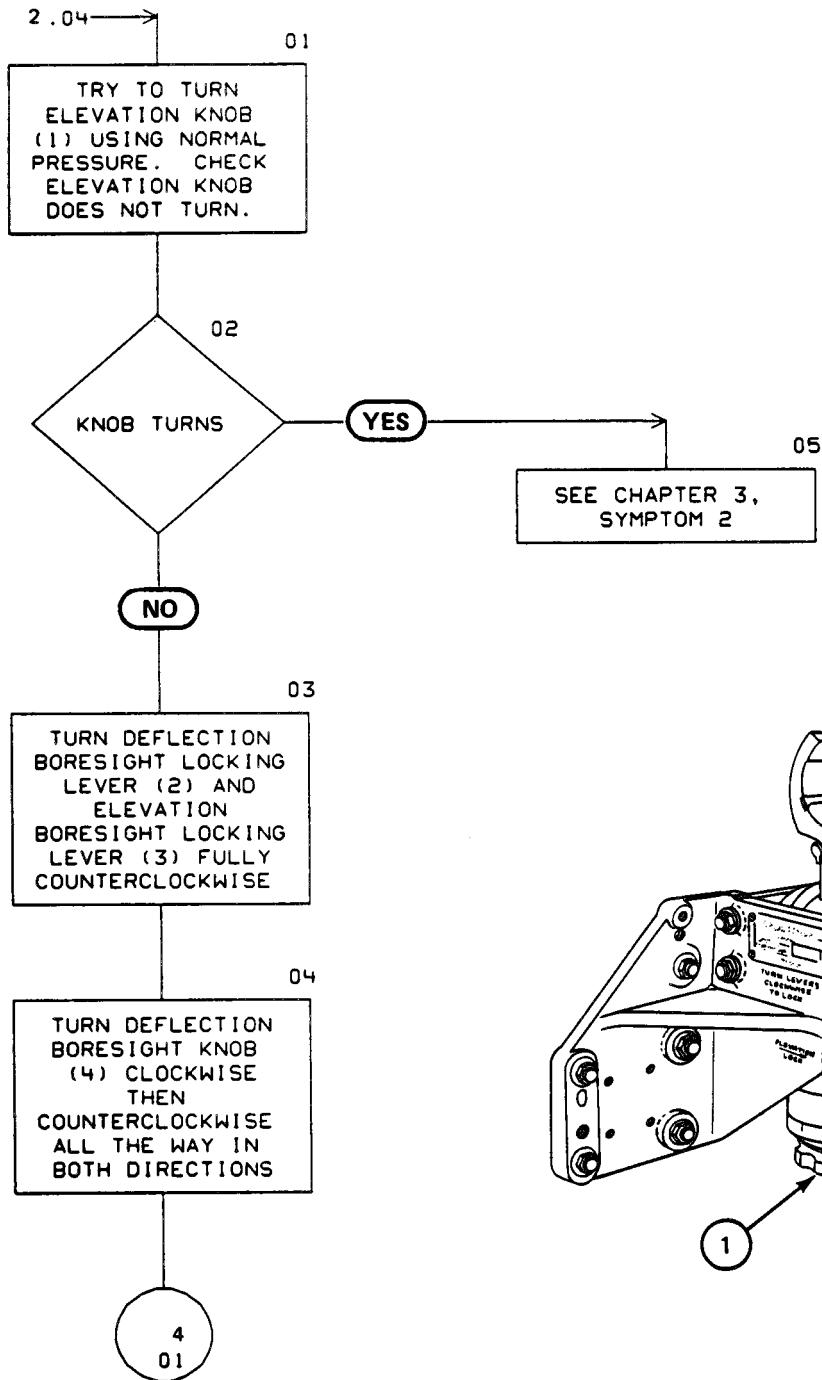

2-2. CHECKOUT (SHEET 4 OF 6)

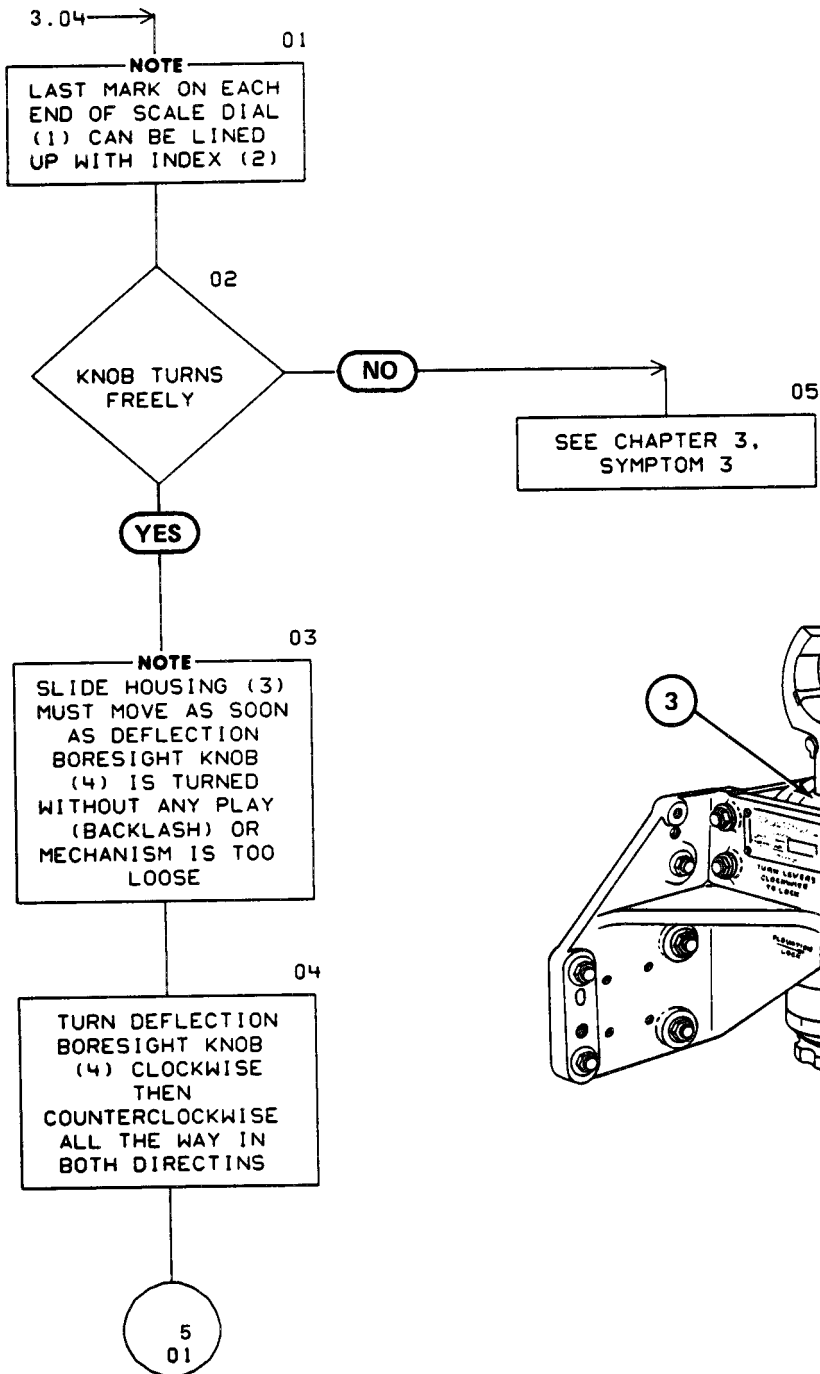

2-2. CHECKOUT (SHEET 5 OF 6)

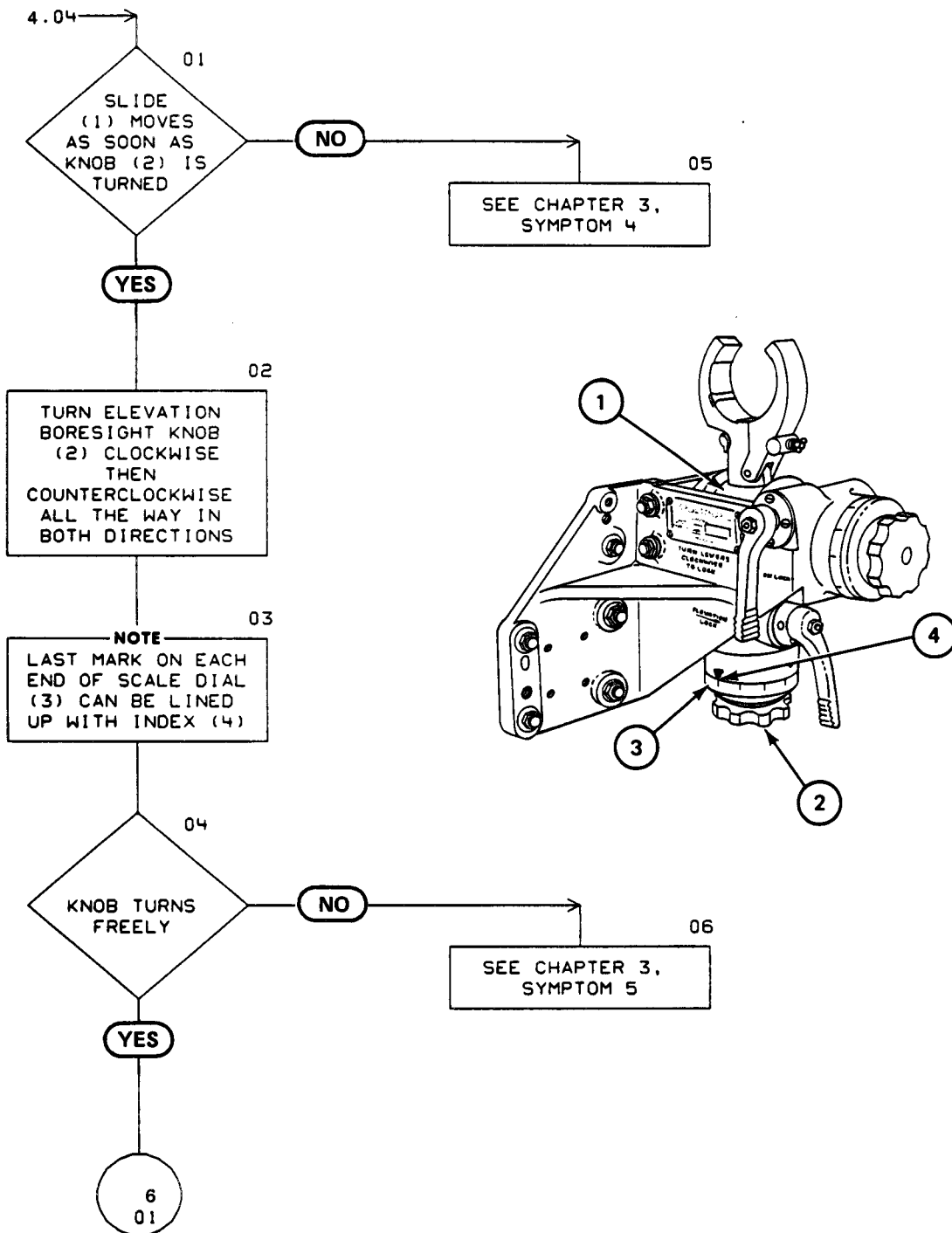

2-2. CHECKOUT (SHEET 6 OF 6)

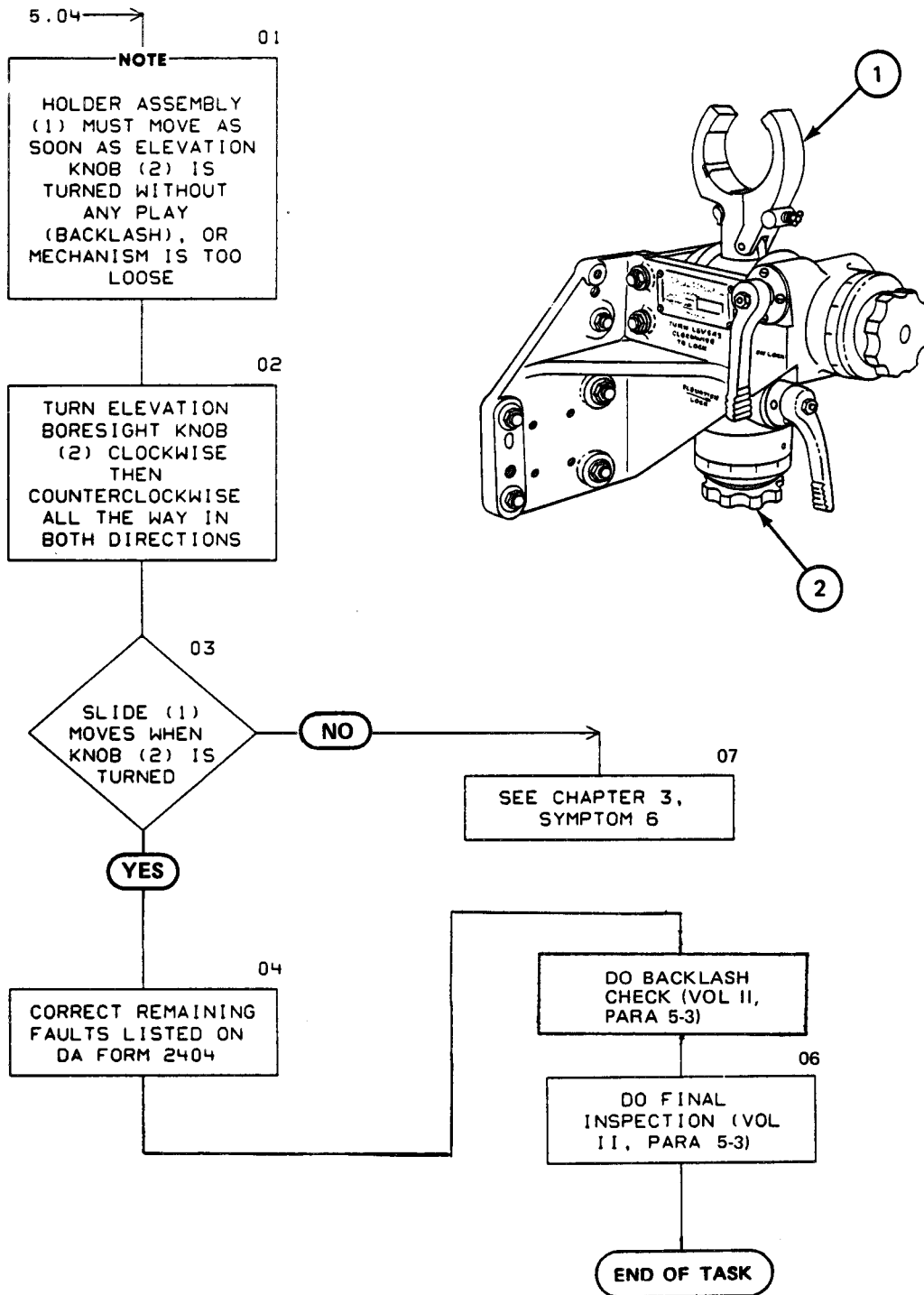

CHAPTER 3
 FAULT SYMPTOM INDEX

Symptom	Fault Isolation Procedure or Maintenance Procedure
1. Deflection locking mechanism does not hold deflection boresight adjusting mechanism	Paragraph 4-2
2. Elevation locking mechanism does not hold elevation boresight adjusting mechanism	Paragraph 4-3
3. Deflection boresight adjusting mechanism does not turn freely (with deflection lock not set)	Paragraph 4-4
4. Deflection boresight adjusting mechanism too loose	a. Tighten ring (Vol II, para 4-13) b. Do backlash check (Vol II, para 5-2)
5. Elevation boresight adjusting mechanism does not turn freely (with elevation lock not set)	Paragraph 4-5
6. Elevation boresight adjusting mechanism too loose	a. Tighten ring (Vol II, para 4-10) b. Do backlash check (Vol II, para 5-2)

CHAPTER 4

FAULT ISOLATION PROCEDURES

4-1. SCOPE

This chapter gives step-by-step procedures to troubleshoot the faults found during checkout. After you replace the part, do the checkout procedure in Chapter 2 again. This is to make sure the new part has fixed the problem.

4-2. DEFLECTION LOCKING MECHANISM DOES NOT HOLD DEFLECTION BORESIGHT ADJUSTING MECHANISM (SHEET 1 OF 3)

TOOLS: 1/4" and 3/8" flat tip screwdriver
7/16" open end wrench

PERSONNEL: One

EQUIPMENT CONDITION: Telescope mount on work bench

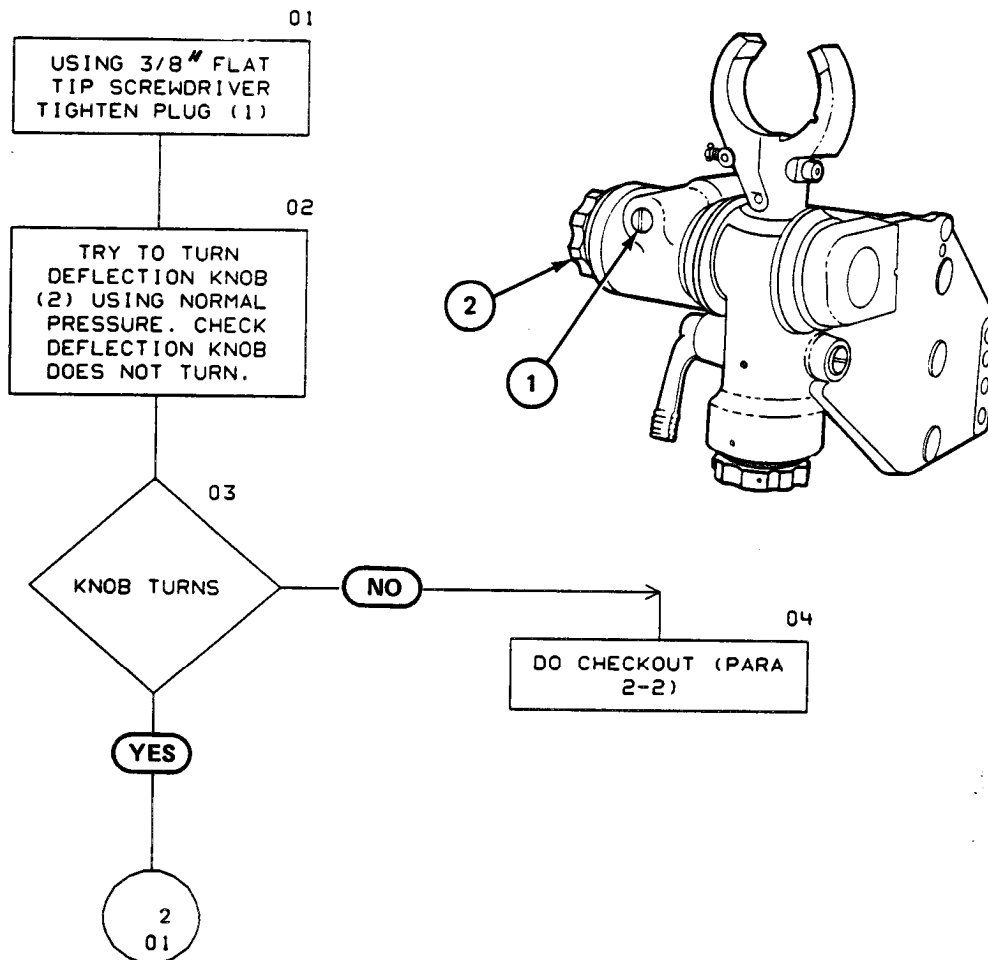

4-2. DEFLECTION LOCKING MECHANISM DOES NOT HOLD DEFLECTION BORESIGHT ADJUSTING MECHANISM (SHEET 2 OF 3)

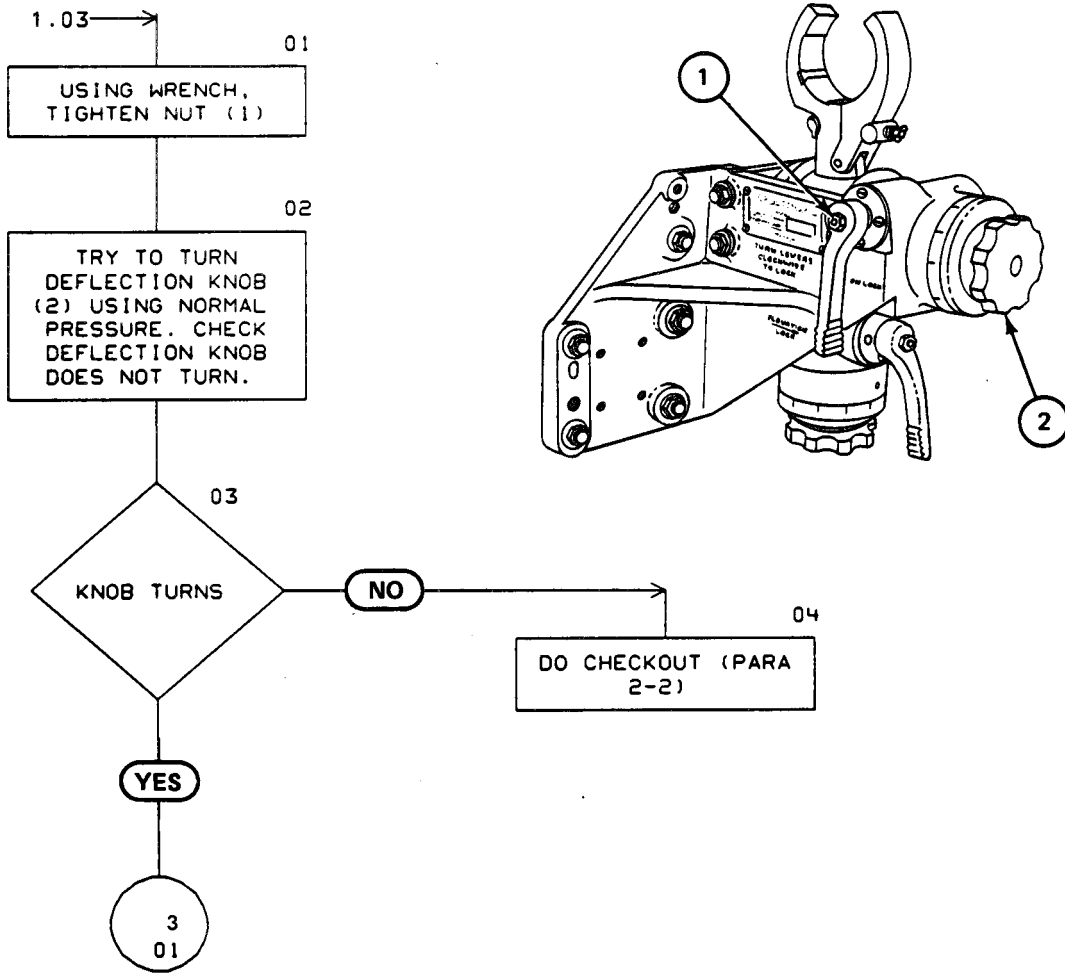

4-2. DEFLECTION LOCKING MECHANISM DOES NOT HOLD DEFLECTION
BORESIGHT ADJUSTING MECHANISM (SHEET 3 OF 3)

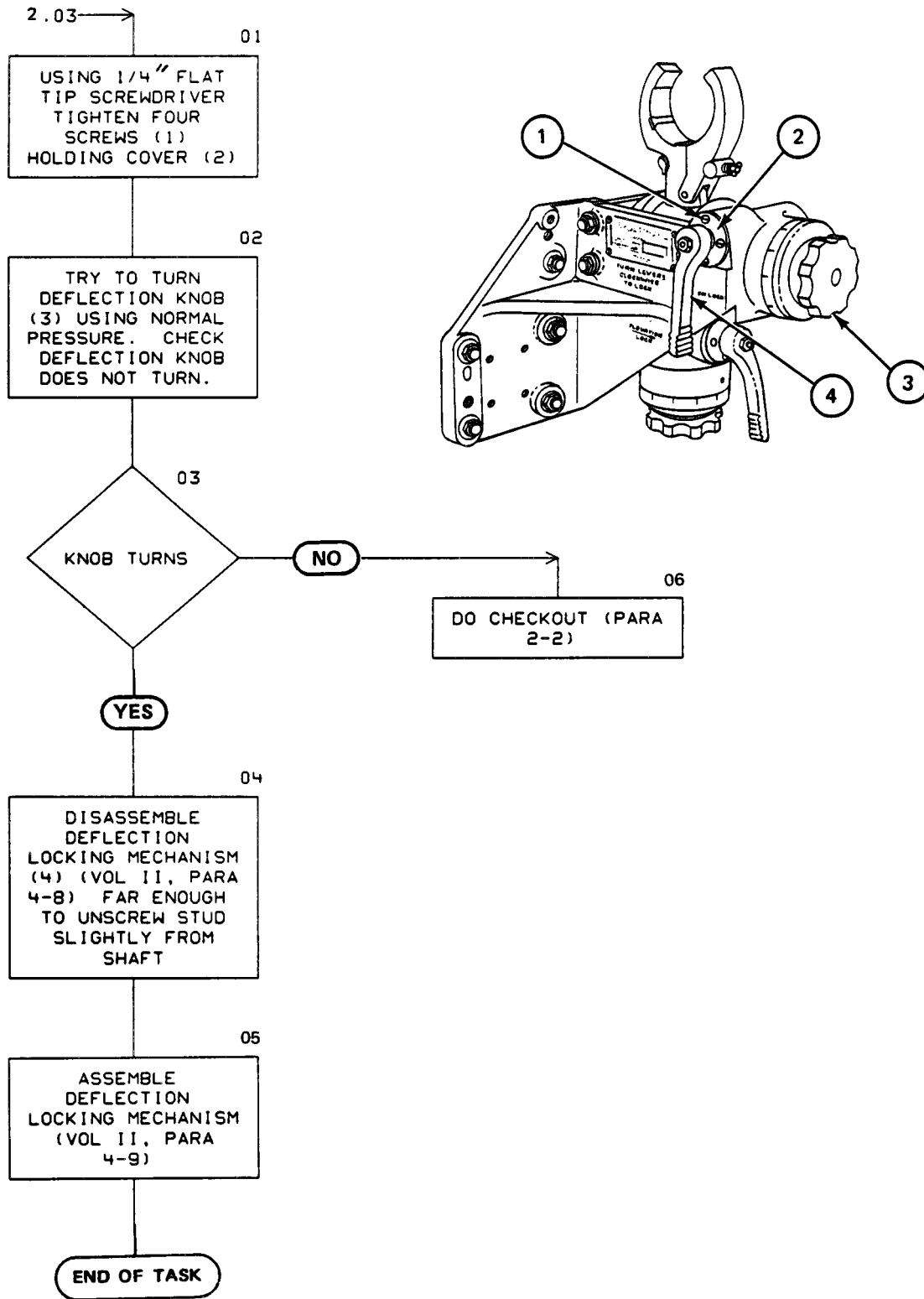

**4-3. ELEVATION LOCKING MECHANISM DOES NOT HOLD ELEVATION
BORESIGHT ADJUSTING MECHANISM (SHEET 1 OF 4)**

TOOLS: 1/4" and 3/8" flat tip screwdriver
7/ 16" open end wrench

PERSONNEL: One

EQUIPMENT CONDITION: Telescope mount on work bench

4-3. ELEVATION LOCKING MECHANISM DOES NOT HOLD ELEVATION BORESIGHT ADJUSTING MECHANISM (SHEET 2 OF 4)

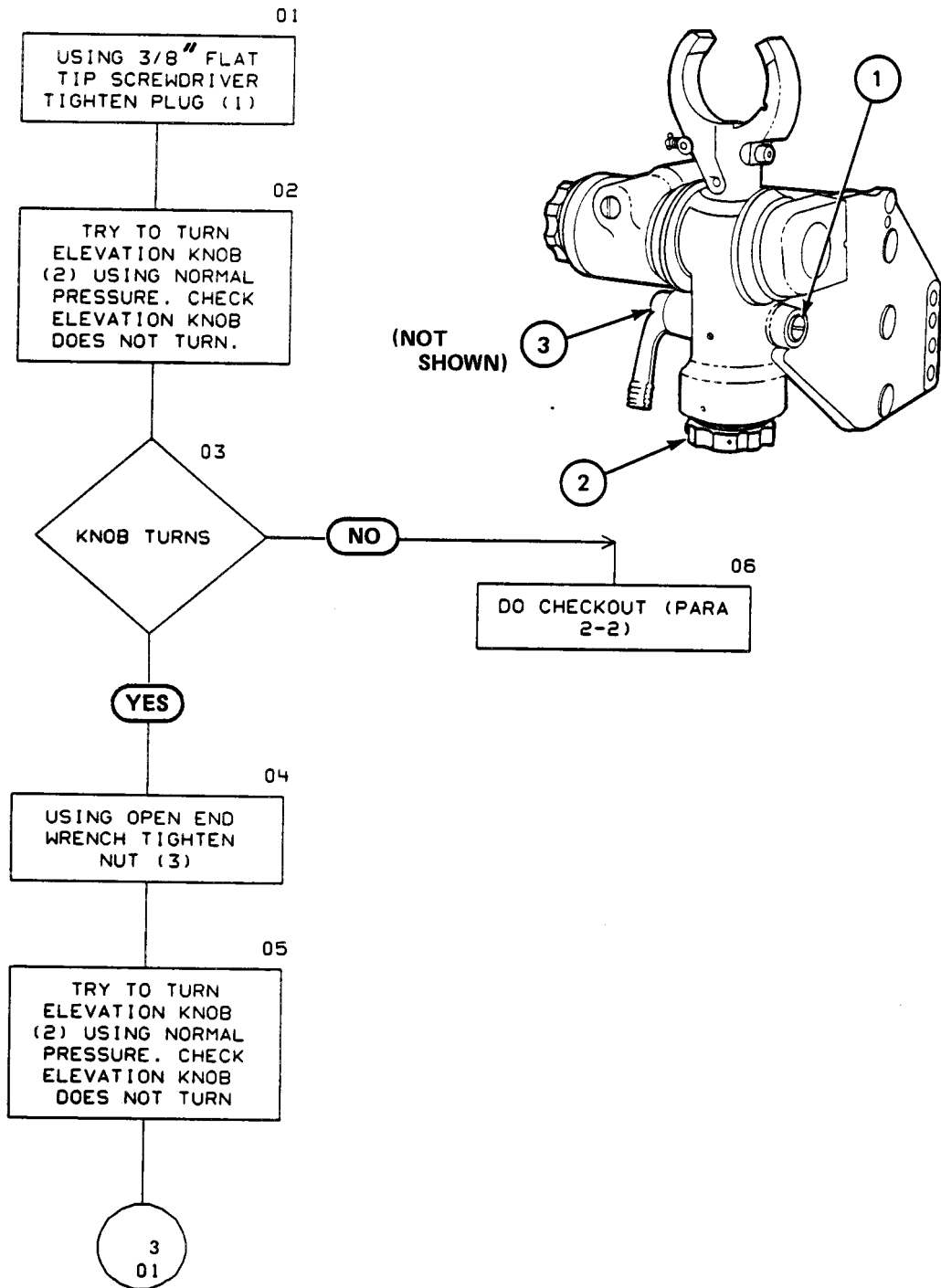

4-3. ELEVATION LOCKING MECHANISM DOES NOT HOLD ELEVATION BORESIGHT ADJUSTING MECHANISM (SHEET 3 OF 4)

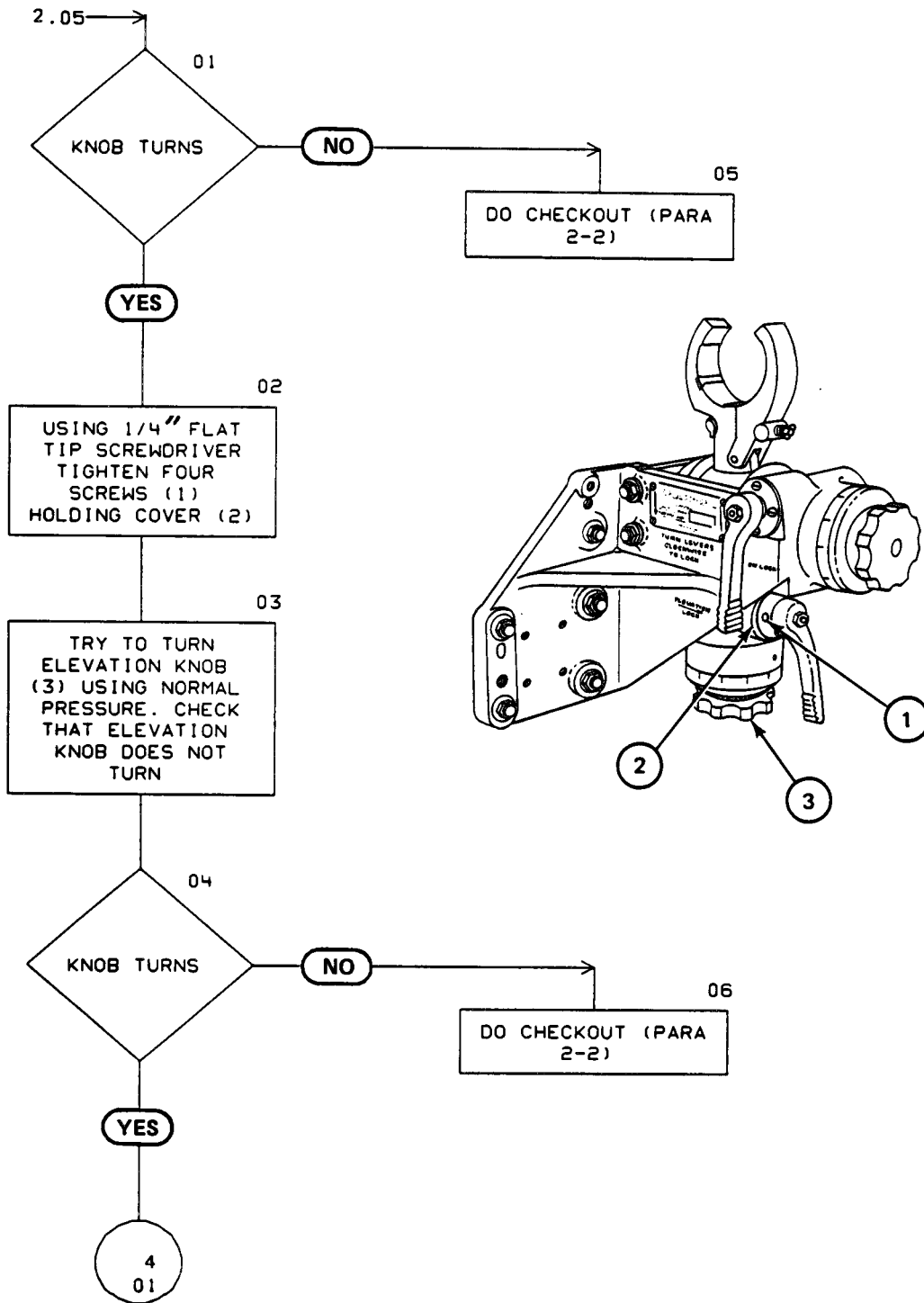

4-3. ELEVATION LOCKING MECHANISM DOES NOT HOLD ELEVATION BORESIGHT ADJUSTING MECHANISM (SHEET 4 OF 4)

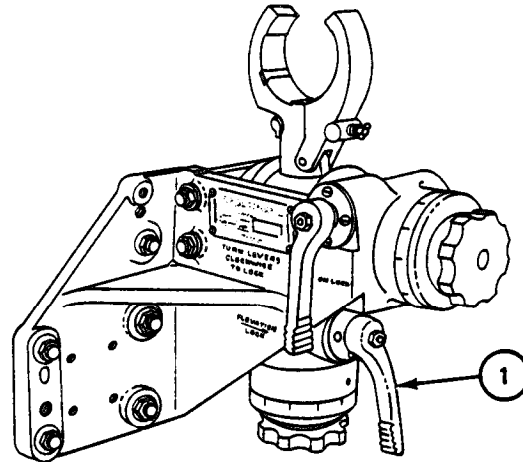
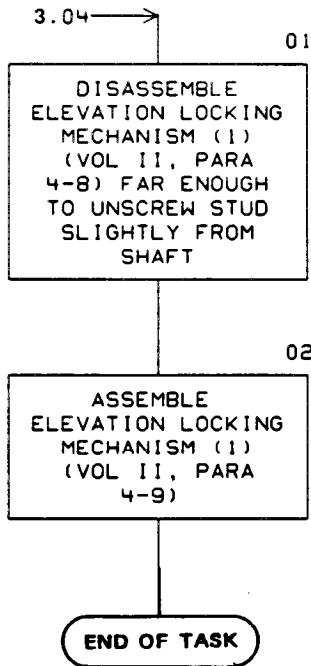

4-4. DEFLECTION BORESIGHT ADJUSTING MECHANISM DOES NOT TURN FREELY (WITH DEFLECTION LOCK NOT SET) (SHEET 1 OF 6)

TOOLS: 3/8" flat tip screwdriver

SUPPLIES: Crocus cloth (item 1, App. A, Vol II)

PERSONNEL: One

REFERENCES: JPG 41 C for cleaning corrosion

EQUIPMENT CONDITION: Telescope mount on work bench

4-4. DEFLECTION BORESIGHT ADJUSTING MECHANISM DOES NOT TURN FREELY (WITH DEFLECTION LOCK NOT SET) (SHEET 2 OF 6)

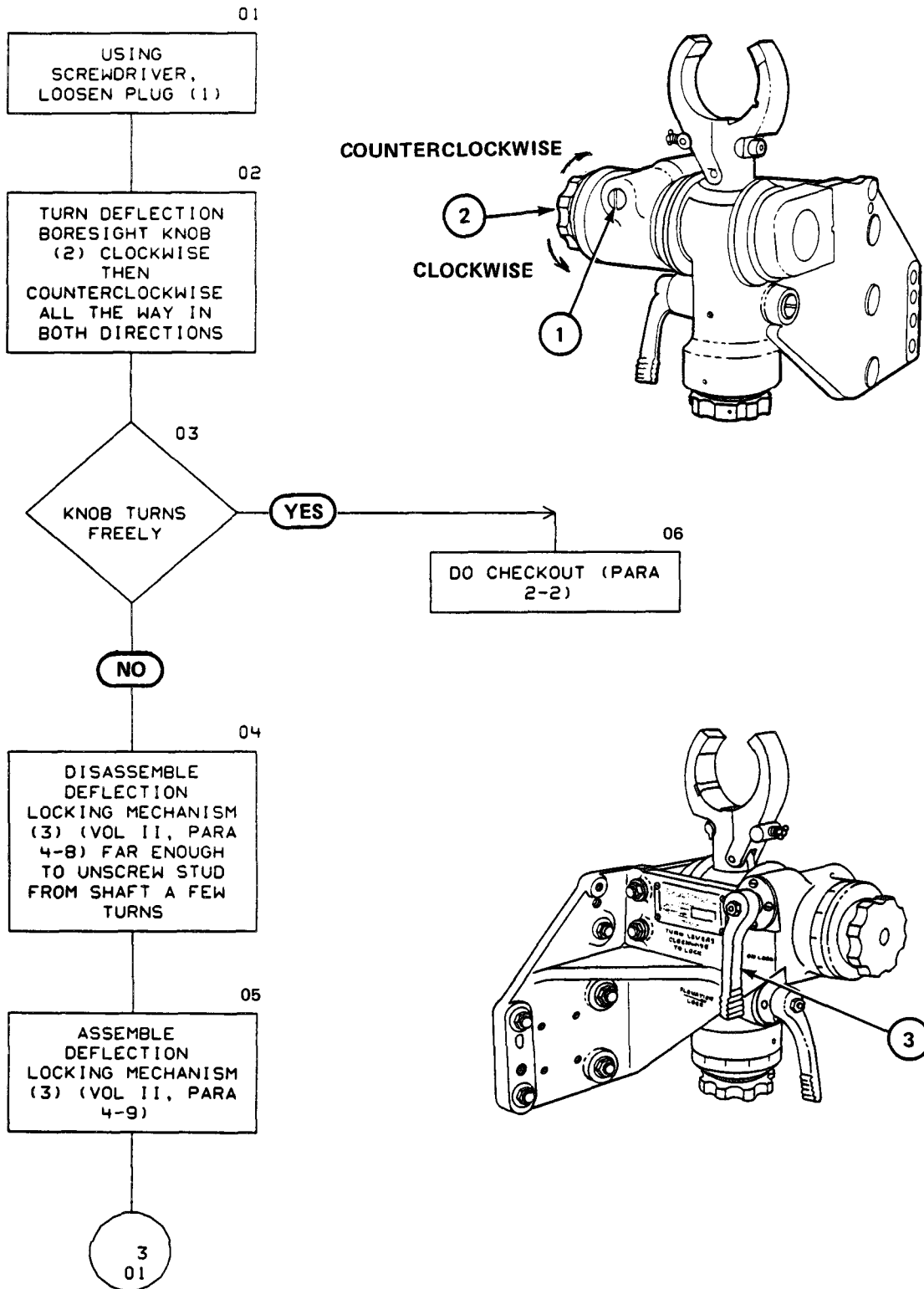

4-4. DEFLECTION BORESIGHT ADJUSTING MECHANISM DOES NOT TURN FREELY (WITH DEFLECTION LOCK NOT SET) (SHEET 3 OF 6)

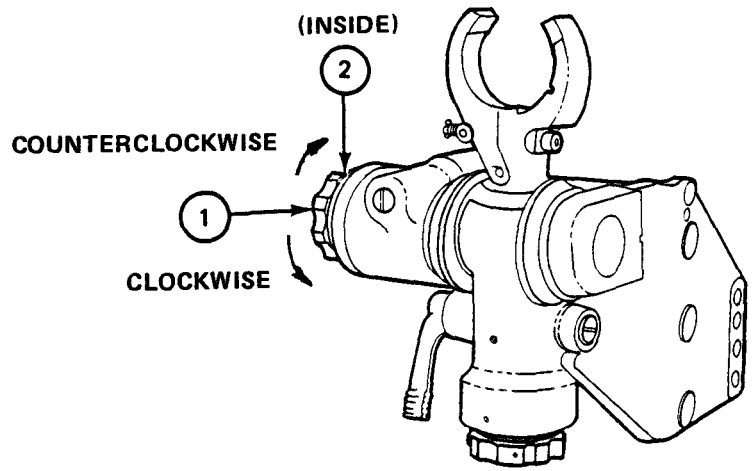
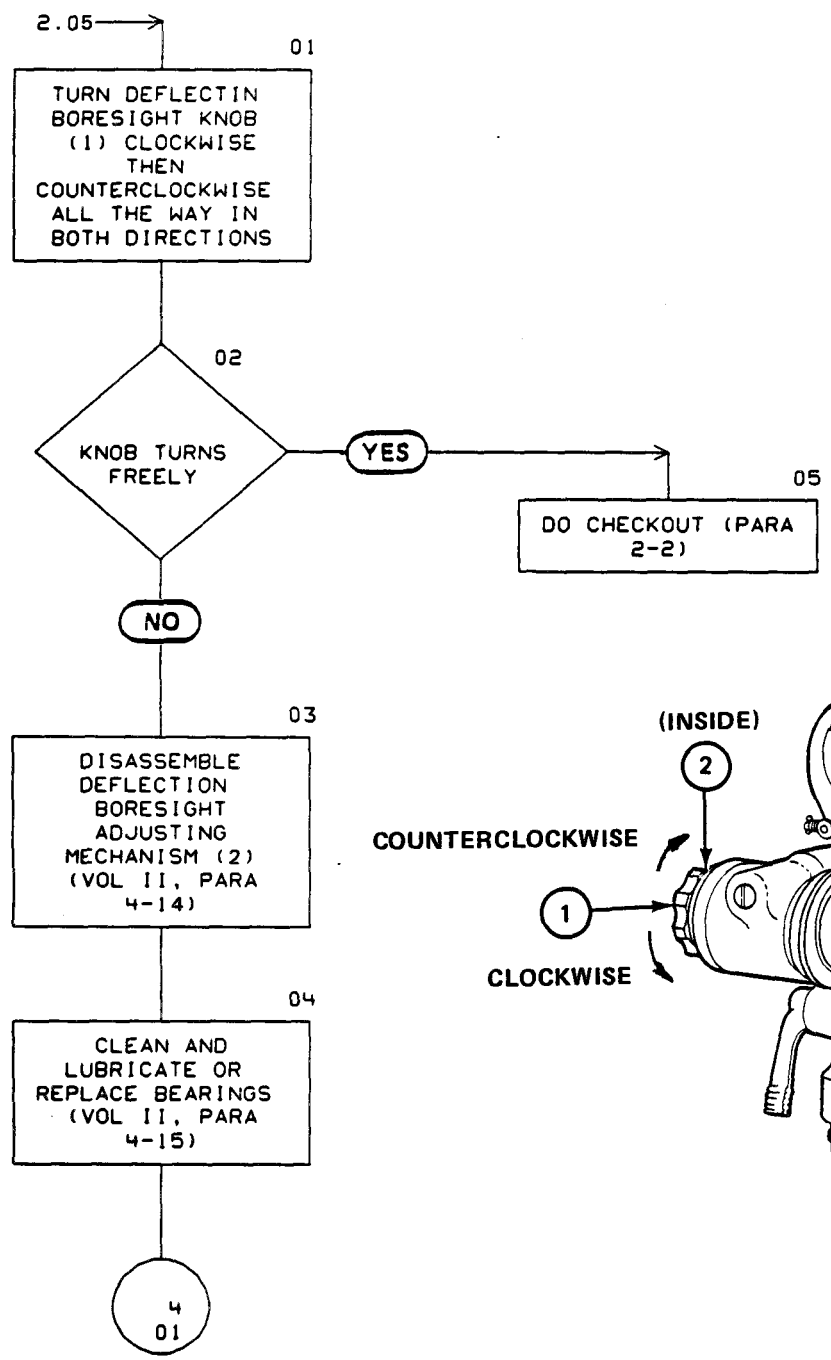

4-4. DEFLECTION BORESIGHT ADJUSTING MECHANISM DOES NOT TURN FREELY (WITH DEFLECTION LOCK NOT SET) (SHEET 4 OF 6)

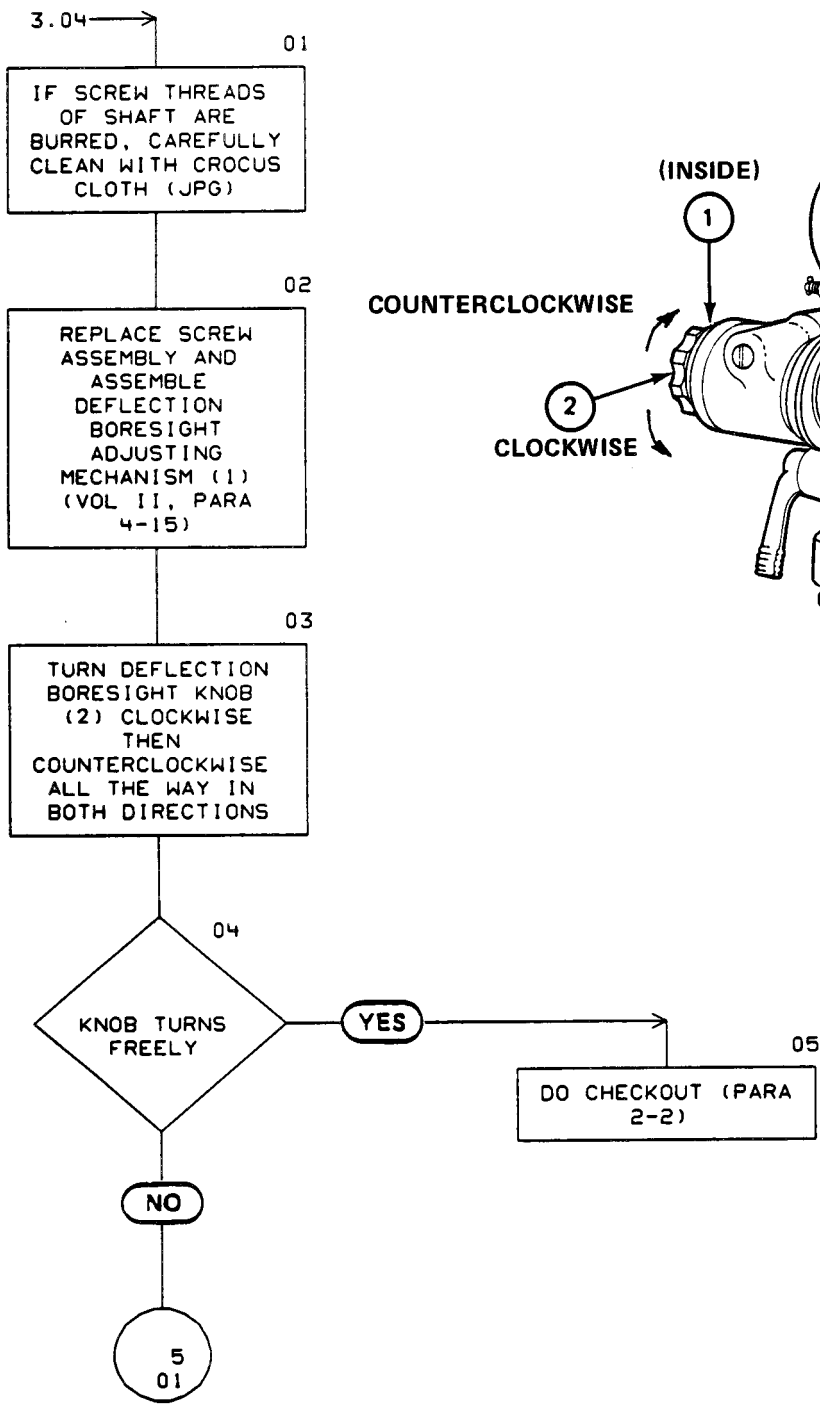

4-4. DEFLECTION BORESIGHT ADJUSTING MECHANISM DOES NOT TURN FREELY (WITH DEFLECTION LOCK NOT SET) (SHEET 5 OF 6)

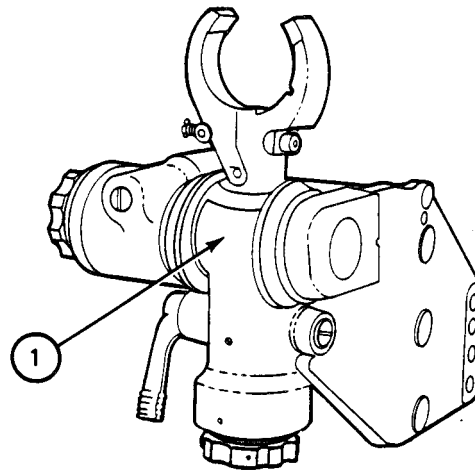
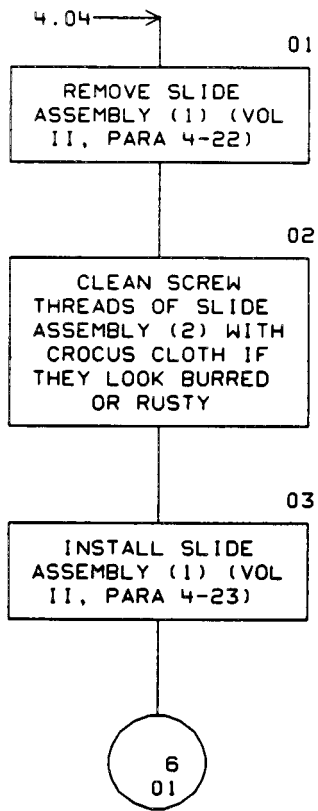

4-4. DEFLECTION BORESIGHT ADJUSTING MECHANISM DOES NOT TURN FREELY (WITH DEFLECTION LOCK NOT SET) (SHEET 6 OF 6)

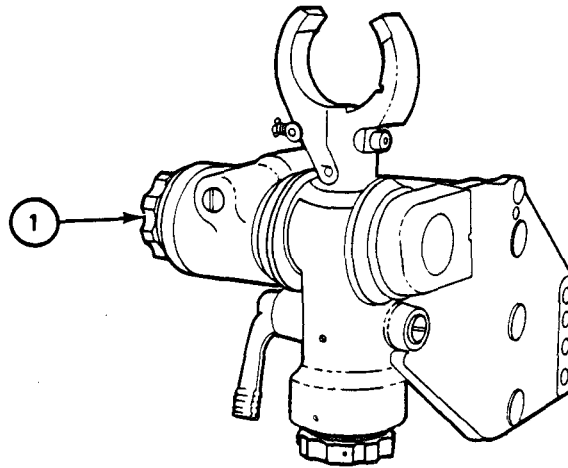
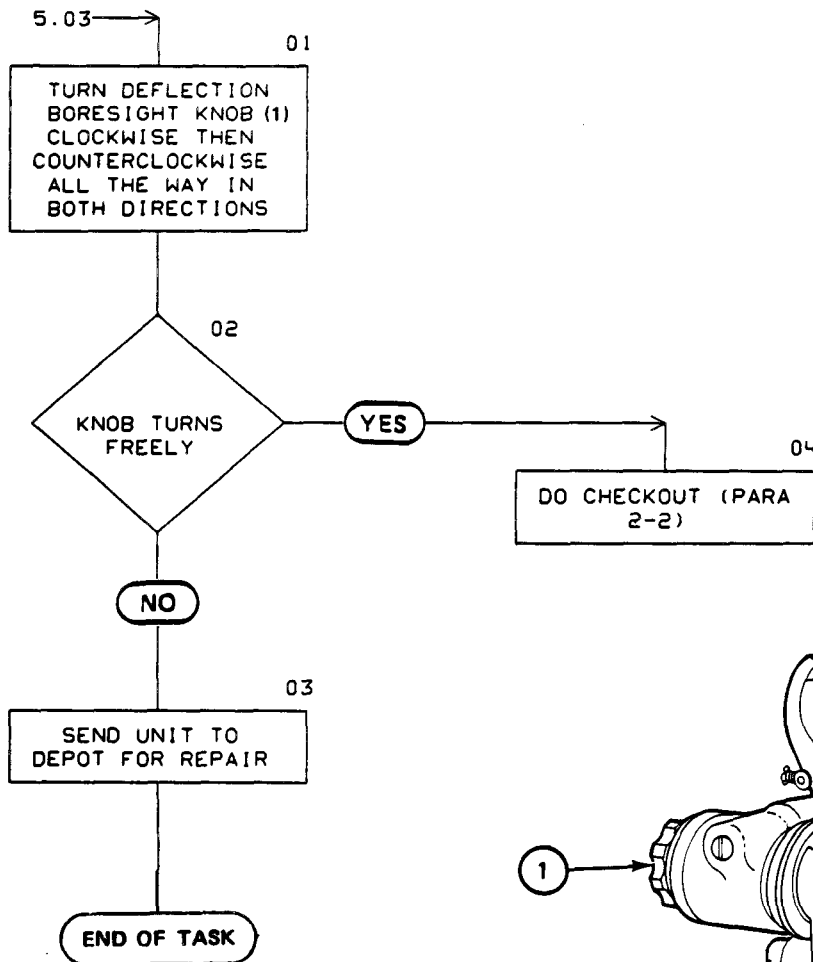

4-5. ELEVATION BORESIGHT ADJUSTING MECHANISM DOES NOT TURN FREELY (WITH ELEVATION LOCK NOT SET) (SHEET 1 OF 5)

TOOLS: 3/8" flat tip screwdriver

SUPPLIES: Crocus cloth (item 1, App. A, Vol II)

PERSONNEL: One

EQUIPMENT CONDITION: Telescope mount on work bench

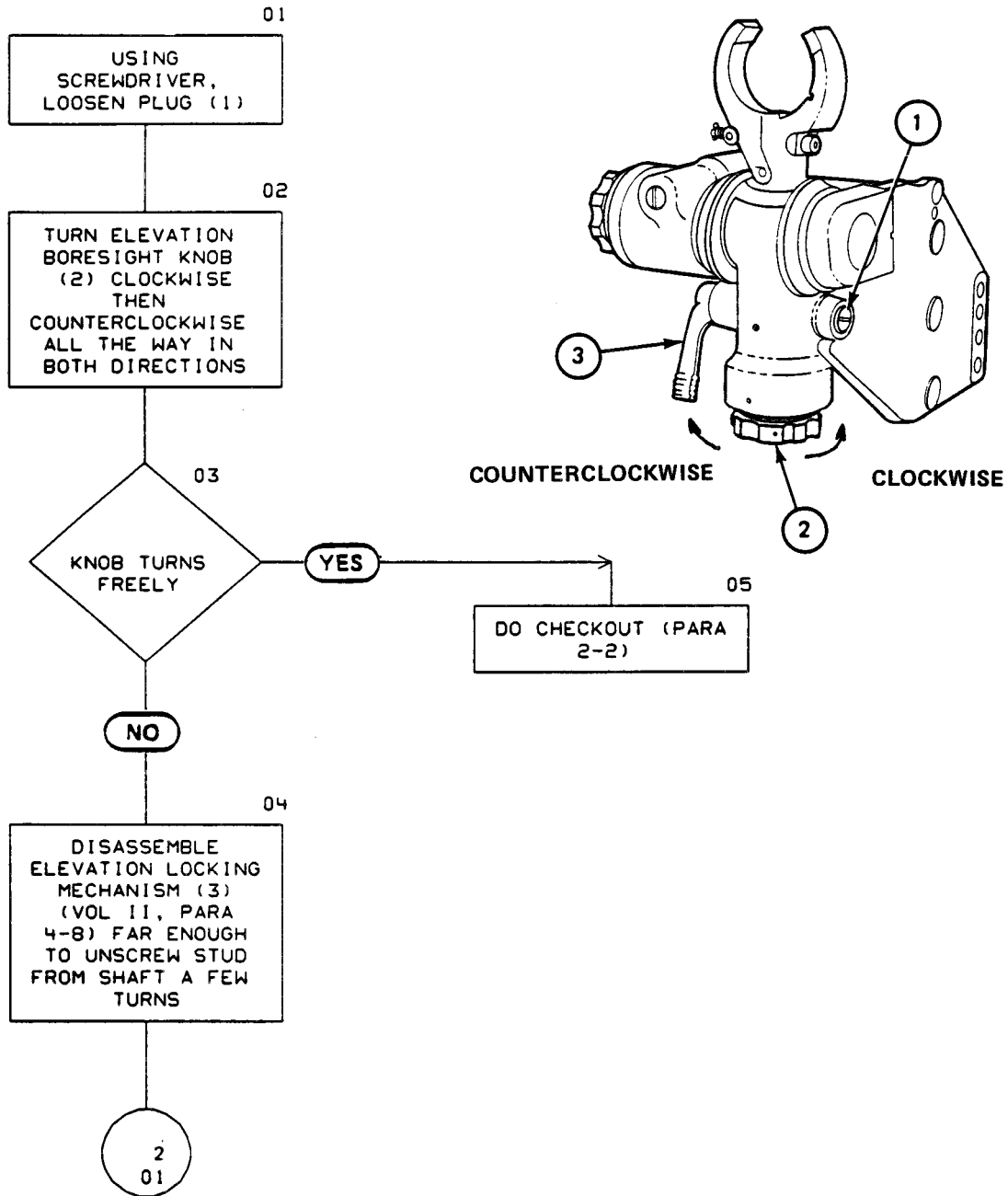

4-5. ELEVATION BORESIGHT ADJUSTING MECHANISM DOES NOT TURN FREELY (WITH ELEVATION LOCK NOT SET) (SHEET 2 OF 5)

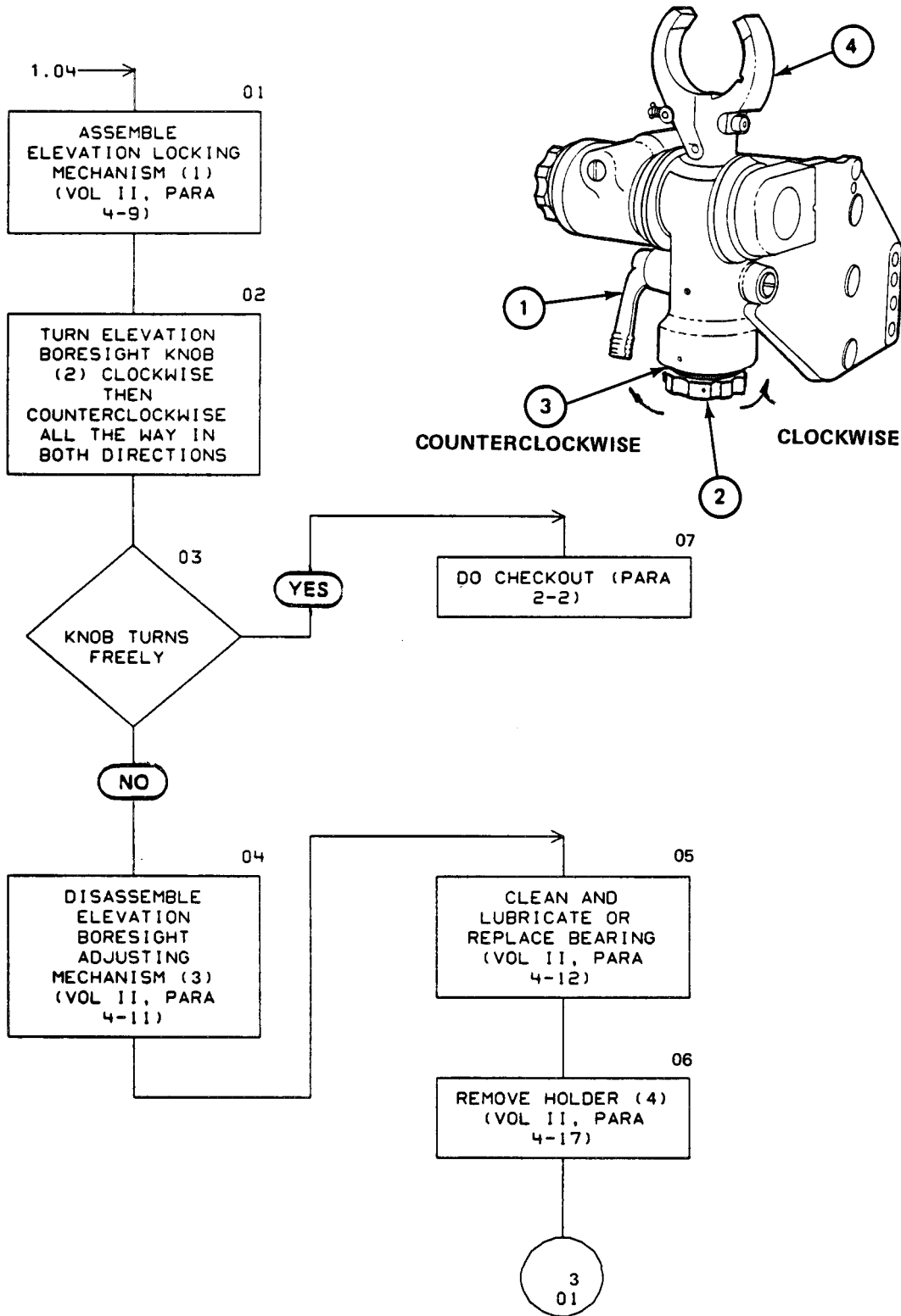

4-5. ELEVATION BORESIGHT ADJUSTING MECHANISM DOES NOT TURN FREELY (WITH ELEVATION LOCK NOT SET) (SHEET 3 OF 5)

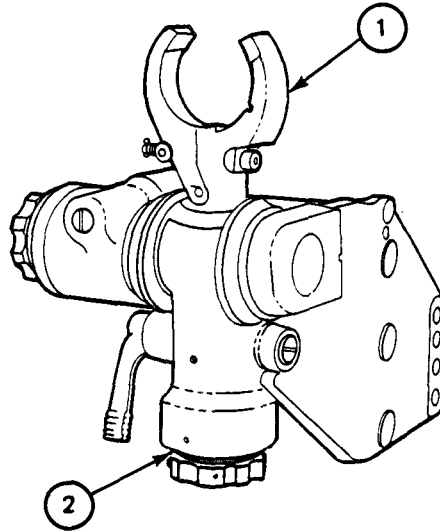
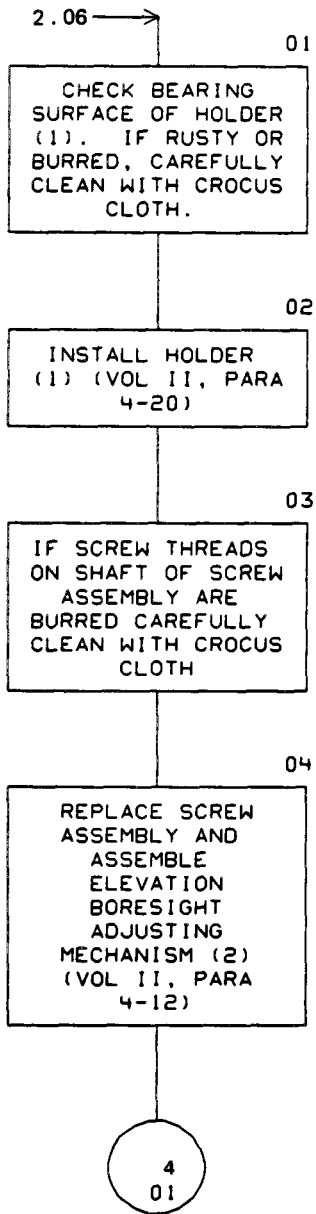

4-5. ELEVATION BORESIGHT ADJUSTING MECHANISM DOES NOT TURN FREELY (WITH ELEVATION LOCK NOT SET) (SHEET 4 OF 5)

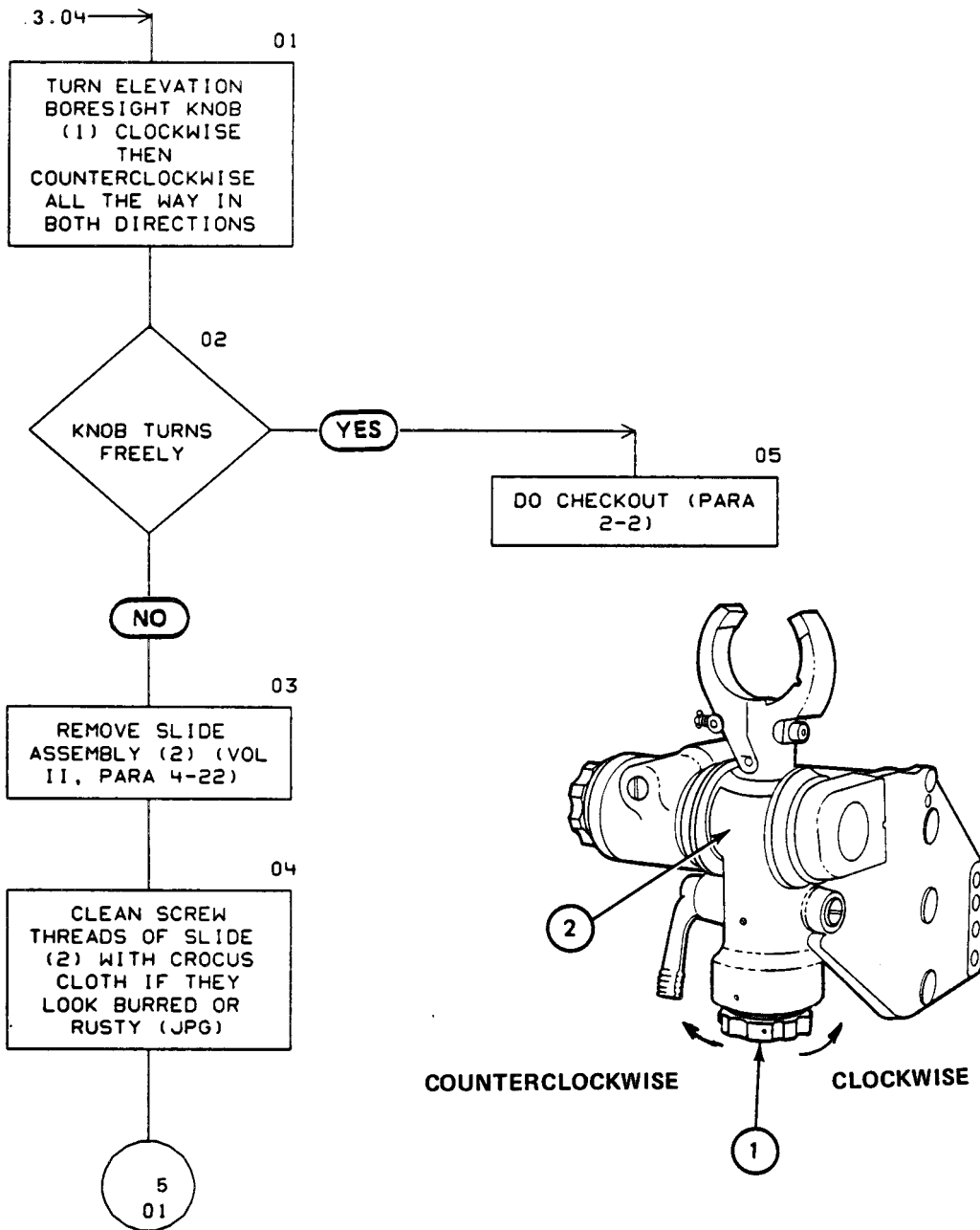

4-5. ELEVATION BORESIGHT ADJUSTING MECHANISM DOES NOT TURN FREELY (WITH ELEVATION LOCK NOT SET) (SHEET 5 OF 5)

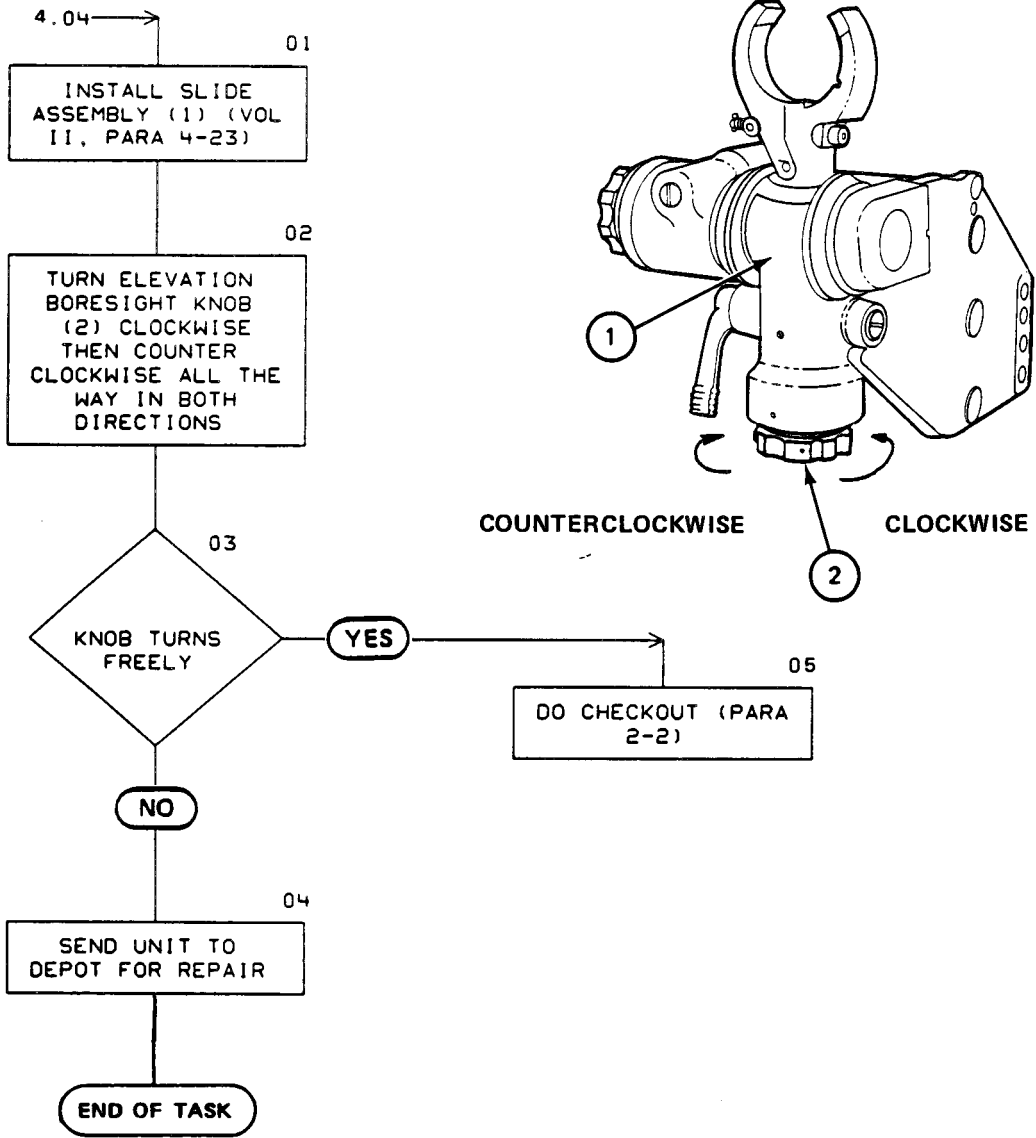

TECHNICAL MANUAL

DIRECT SUPPORT AND
GENERAL SUPPORT
MAINTENANCE MANUAL INCLUDING
REPAIR PARTS AND SPECIAL
TOOLS LIST (INCLUDING DEPOT
MAINTENANCE REPAIR PARTS)

VOLUME II-MAINTENANCE

MOUNT, TELESCOPE: M114

CHAPTER 1

INTRODUCTION

Section 1. GENERAL

1-1. SCOPE

This volume contains the maintenance requirements and procedures for direct support and general support (DS/GS) maintenance for the M114 Telescope Mount. See Volume I for troubleshooting procedures.

1-2. ORGANIZATION

a. Chapter 2, General Maintenance Information, lists the maintenance items and references other procedures that are necessary to do the maintenance in this manual.

b. Chapter 3, Inspection Upon Receipt, gives the kind of defects to look for when the telescope mount is returned to DS/GS. A complete inspection should be made and faults listed on DA Form 2404 before any repairs are made.

c. Chapter 4, Maintenance Procedures, give step-by-step procedures to repair faults found during inspection or troubleshooting.

d. Chapter 5, Final Inspection, gives procedures to be done after repair to make sure that the telescope mount works.

e. Chapter 6, Packaging, gives procedures for packaging the telescope mount for storage or shipment.

f. Appendix A, Expendable Supplies and Materials, lists the supplies and materials needed to repair the telescope mount.

g. Appendix B, Maintenance Task Index, helps you find the necessary maintenance tasks for the telescope mount.

h. Appendix C, Fabricated Tool, gives you information to make the spring wrench necessary to do the maintenance procedures.

i. Appendix D, Repair Parts and Special Tools List, gives a listing of repair parts, special tools, and support equipment required for the performance of direct support, general support, and depot maintenance of the telescope mount.

Section 2. DESCRIPTION AND DATA

1-3. DESCRIPTION

Telescope Mount MI 14 is used to hold and position telescope MI 05 for use as the backup fire control system in the M60, M60A1, M728, and M48A5 tanks.

The mount has a base housing assembly (1), which is attached to the mount assembly recoil of the tank, an adjustable slide assembly (2) supported horizontally in the housing, and an adjustable holder assembly (3) that can move vertically within the slide. The top of the holder assembly (3) forms an adjustable telescope clamp.

The base housing assembly (1) is the main support of the telescope mount. The slide assembly (2) is supported on one side by a slide bearing housing and on the other side by an extension of the base housing. Deflection can be changed or adjusted by rotating the deflection adjusting knob (4), which causes the slide assembly (2) to move sideways.

The slide assembly (2) contains the holder assembly (5). To adjust elevation, the holder assembly (5) can be moved up and down in the slide assembly by rotating the elevation adjusting knob (6).

The two calibrated scale dials (7) are connected to the boresight knobs (4) and (6) that are used to adjust the telescope in deflection and elevation. The scale dials indicate the scope of the adjustments and the deflection and elevation settings.

The lock levers (8) clamp the slide and holder to the desired adjustments when turned fully clockwise.

1-3. DESCRIPTION (CONT)

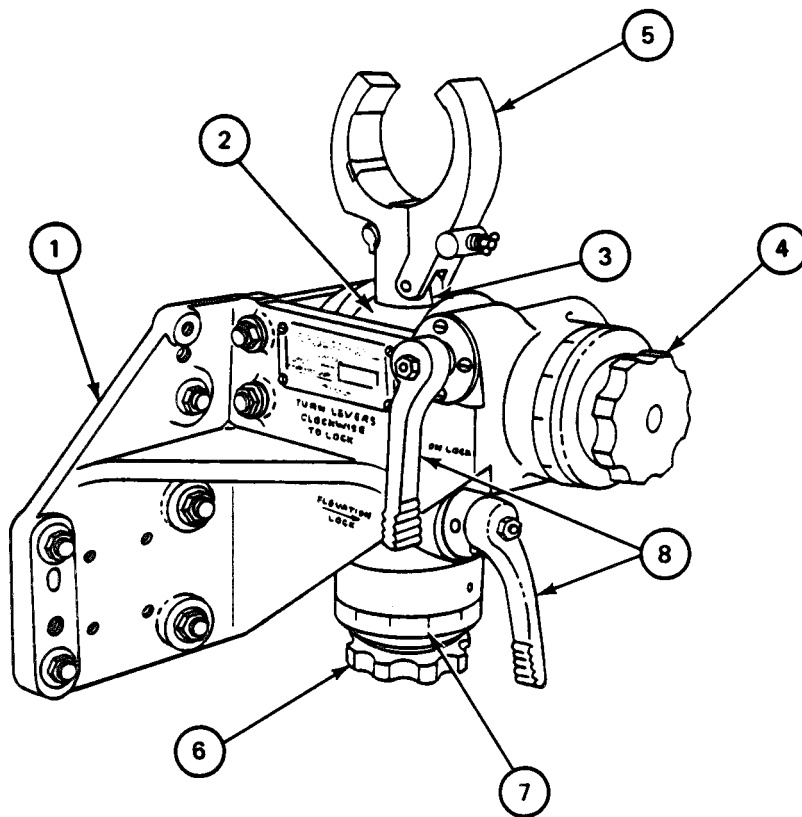
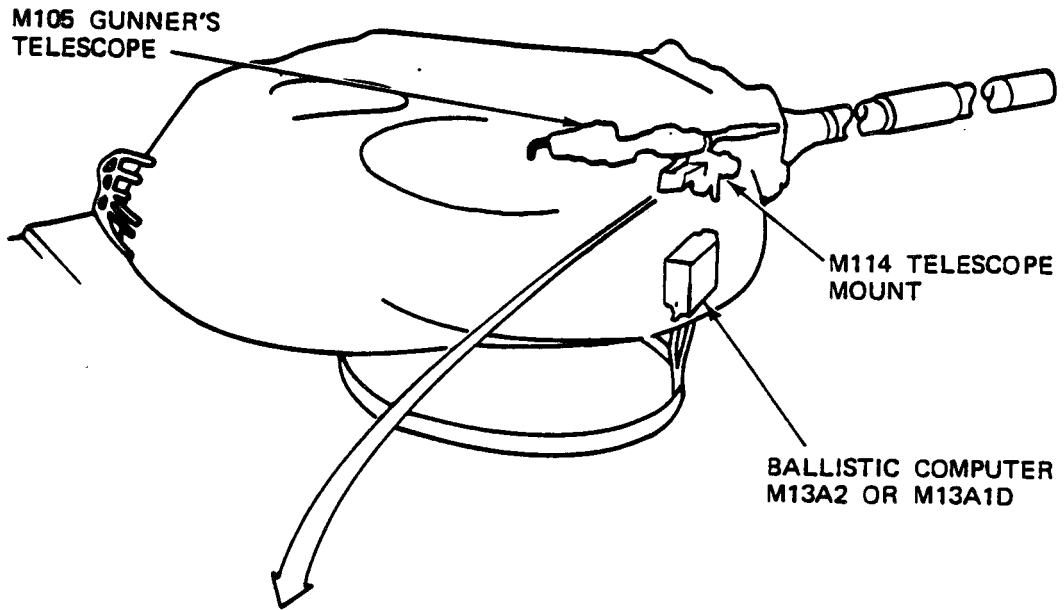

1-4. TABULATED DATA

Length	10-3/4 in. (approx)
Height	13 in. (approx)
Width	10-1/4 in. (approx)
Deflection	
Adjustment	40 mils
Elevation	
Adjustment	40 mils
Weight	48 lb. (approx)

CHAPTER 2

GENERAL MAINTENANCE INFORMATION

Section 1. GENERAL

2-1. SCOPE

This chapter tells you what special tools and test equipment are needed to repair the M114 Telescope Mount and where to find other information for the maintenance procedures in this volume.

Section 2. REFERENCE DOCUMENTS

2-2. GENERAL MAINTENANCE

General maintenance procedures for fire control materiel are in TM 9-254 and Job Performance Guide 113-091-9000R (JPG 41C).

2-3. CLEANING

General cleaning procedures are in JPG 41C.

2-4. PAINTING

General painting procedures are in TM 43-0139,

2-5. SEALING

General instructions for how to use sealing compounds are in JPG 41C.

2-6. LUBRICATION

General instructions for how to use lubricants are in JPG 41C.

Section 3. SAFETY PROCEDURES

2-7. GENERAL PROCEDURE

General safety procedures are in AR 385-40 Safety: Accident Reporting and Records,

Section 4. SPECIAL TOOLS AND TEST EQUIPMENT

2-8. TOOLS AND TEST EQUIPMENT

The only special tool needed to repair the M114 Telescope Mount is the spring wrench (see Appendix C)

CHAPTER 3

INSPECTION UPON RECEIPT

3-1. SCOPE

This chapter gives procedures to check the M114 Telescope Mount for faults you can see when it is received in the DS /GS shop. It also tells you what part of this volume to go to for various repairs. A complete inspection should be made and all faults listed on DA Form 2404 before taking any maintenance actions.

3-2. INSPECTION UPON RECEIPT

TOOLS: 3/32" and 5/64" socket head screw key (Allen wrench or equivalent)

9/ 16" box wrench

7/16" open end wrench

1/4", 3/8" and 3/ 16" flat tip screwdriver

SUPPLIES: Paint (item 4, App. A)
Primer (item 5, App. A)

PERSONNEL: One

REFERENCES: JPG 41C for: Cleaning
Lubricating
Peening screw threads
Completing DA Form 2404
TM 43-0139 for painting

EQUIPMENT CONDITION: Telescope mount on work bench or in vehicle

3-2. INSPECTION UPON RECEIPT (CONT)

FRAME 1			
Step	Procedure	Maintenance Action	Reference
1.	Clean exterior of telescope mount and check for cracks or dents.	If cracks or dents are found, tell your supervisor.	. . .
2.	Check that cotter pin (1) or spring pin (1) is not missing.	Replace if missing.	Para 4-16
3.	Check that screw (2) is not missing.	Replace if missing.	Para 4-16
4.	Check dust-moisture seal boots (3) are not torn.	Replace if torn.	Para 4-21
5.	Using 1/4" flat tip screwdriver, check that eight screws (4) are tight.	Tighten. Replace if missing.	. . .
6.	Using 7/16" open end wrench, check that two nuts (5) are tight.	Tighten. Replace if missing.	. . .
7.	Using 1/4" flat tip screwdriver, check that four screws (6) are tight.	Tighten. Replace if missing.	. . .
8.	Using 5/64" Allen wrench, check that setscrew (7) is tight.	Tighten. Replace if missing.	. . .
GO TO FRAME 2			

3-2. INSPECTION UPON RECEIPT (CONT)

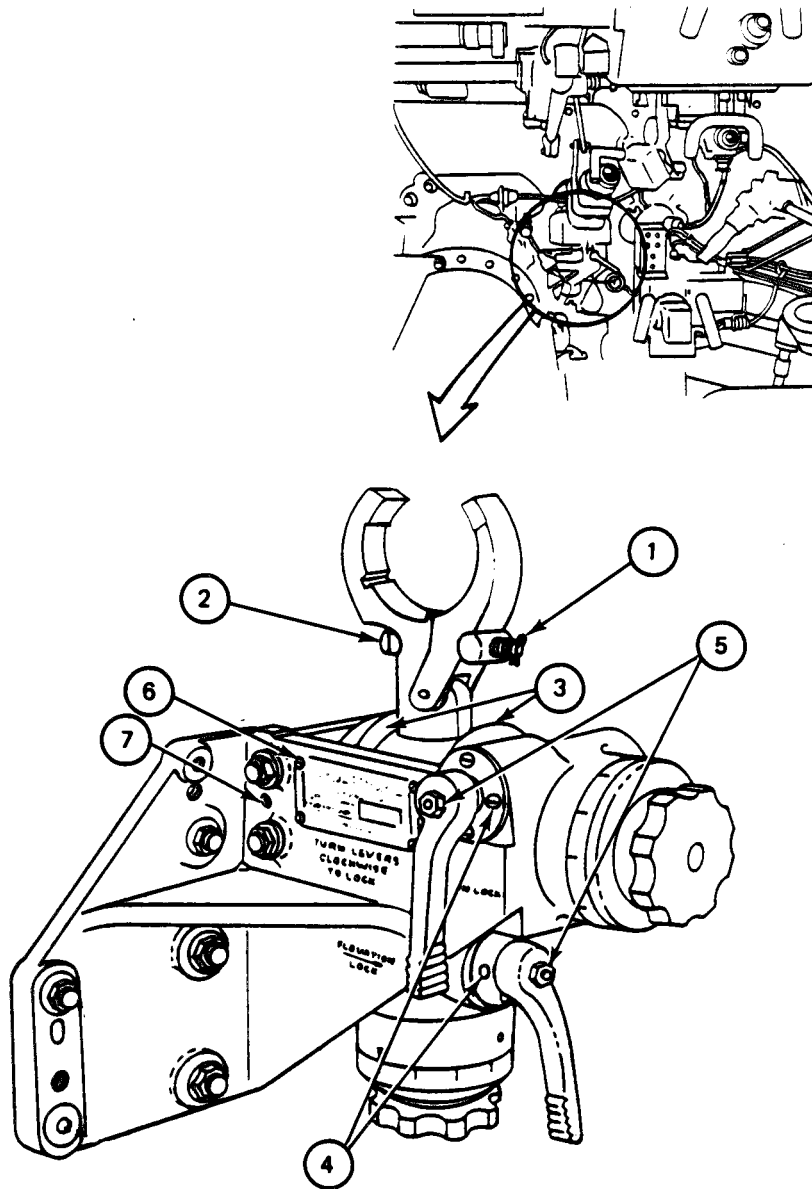

3-2. INSPECTION UPON RECEIPT (CONT)

FRAME 2			
Step	Procedure	Maintenance Action	Reference
1.	Check identification plate (1) can be read.	Tell your supervisor.	. . .
2.	Check decals (2) are in place and can be read.	Replace if missing or not readable.	Para 4-3
3.	Check that elevation and deflection boresight mechanisms (3) will not turn when lock levers (4) are in locked position.	Replace worn part(s) on elevation or deflection locking mechanism.	Para 4-7
4.	Check that elevation and deflection boresight mechanisms (3) do not bind when lock levers (4) are in unlocked position.	Replace worn part(s) on elevation or deflection boresight mechanism.	Para 4-10 and 4-13
5.	Using 9/ 16" box wrench, check that two screws (5) are tight.	Tighten. Replace if missing.	. . .
6.	Check that pin (6) is staked at both ends. GO TO FRAME 3	Stake, if not staked.	Para 4-19

3-2. INSPECTION UPON RECEIPT (CONT)

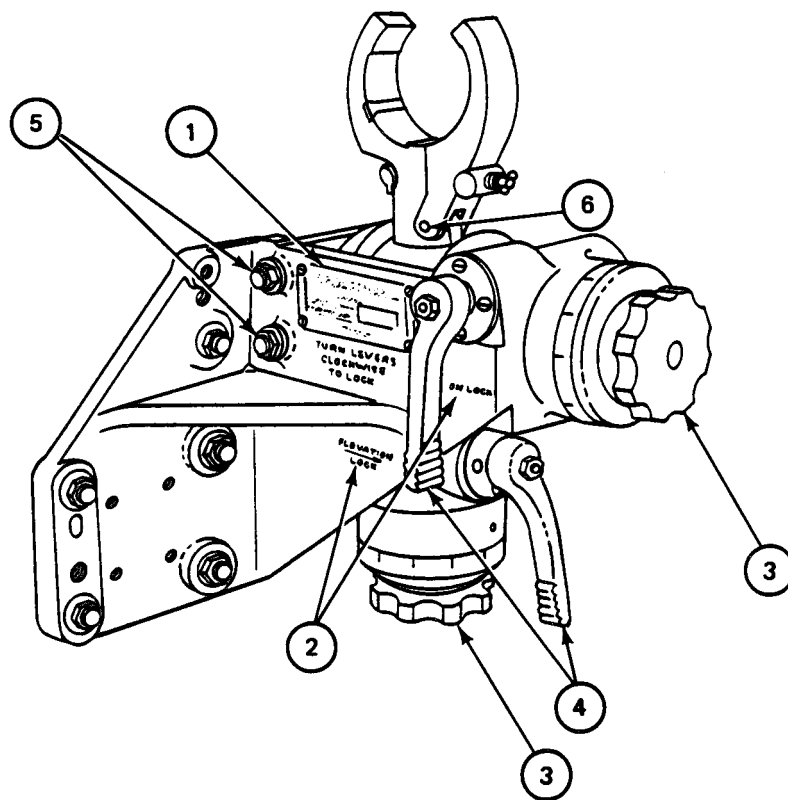

3-2. INSPECTION UPON RECEIPT (CONT)

FRAME 3			
Step	Procedure	Maintenance Action	Reference
1.	Using 3/ 8" flat tip screwdriver, check that plug (1) is tight.	Tighten. Replace if missing.	. . .
2.	Using 3/32" Allen wrench, check that four setscrews (2) are tight.	Tighten. Replace if missing.	. . .
3.	Using 3/32" Allen wrench, check that two setscrews (3) are tight.	Tighten. Replace if missing.	. . .
4.	Using 3/ 16" flat tip screwdriver, check that setscrew (4) is tight.	Tighten. Replace if missing.	. . .
5.	Check that dial scales (5) are not dented, that they turn freely without binding and that graduations can be seen clearly.	Replace dial scale.	Para 4-10 and 4-13
6.	Check that plug (6) is not missing.	Replace if missing.	Para 4-23
7.	Using 3/ 8" flat tip screwdriver, check that plug (7) is tight.	Tighten. Replace if missing.	Para 4-9
8.	Check telescope mount for chipped or scratched paint.	Paint chipped or scratched area.	TM 43-0139
<p>NOTE</p> <p>FOLLOW-ON MAINTENANCE</p> <p>Correct faults listed on DA Form 2404 that may affect the checkout procedure. Do checkout procedure (Vol I, para 2-2)</p> <p>END OF TASK</p>			

3-2. INSPECTION UPON RECEIPT (CONT)

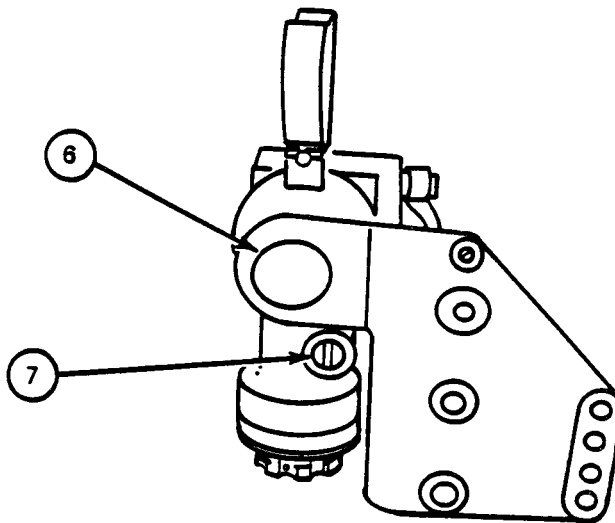
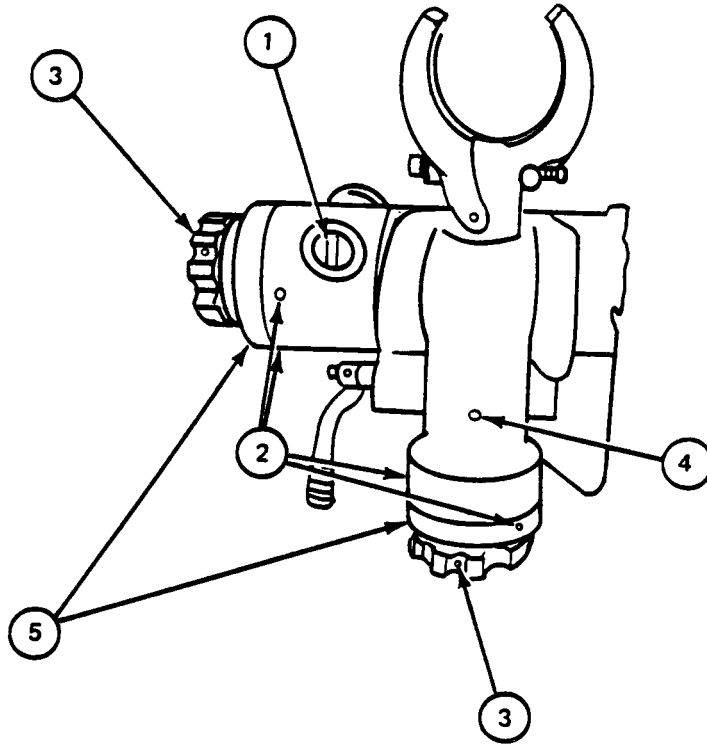

CHAPTER 4 MAINTENANCE PROCEDURES

Section 1. GENERAL

4-1. SCOPE

This chapter gives maintenance procedures for the M114 Telescope Mount.

4-2. LIST OF TELESCOPE MOUNT ITEMS CONTAINED IN THIS CHAPTER

Item	Figure Index No.	Reference (para)
Decals	1	4-3
Telescope Mount	2	4-4
Deflection and Elevation Locking Mechanisms	3	4-7
Elevation Boresight Adjusting Mechanism	4	4-10
Deflection Boresight Adjusting Mechanism	5	4-16
Holder Assembly	6	4-20
Slide Assembly and Boots	7, 8	4-21

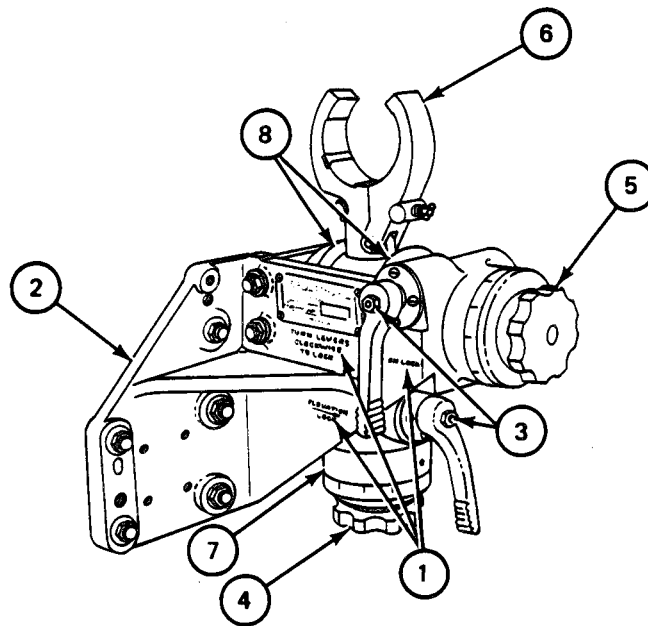

Section 2. DECALS

4-3. DECAL REMOVAL AND REPLACEMENT

TOOLS: Razor blade or equivalent scraping instrument

SUPPLIES: Dry cleaning solvent or equivalent (item 7, App. A)

PERSONNEL: One

REFERENCES: JPG 4IC for cleaning

EQUIPMENT CONDITION: Telescope mount on work bench or in tank

FRAME 1	
Step	Procedure
1.	Using razor blade or equivalent, scrape decal (1), (2) or (3) from mounting surface (4).
2.	Using clean cloth dampened with solvent, clean area to remove glue, dirt or grease (JPG).
3.	Using instructions of back of decal (1), (2) or (3), put on new decals.
<p>NOTE</p> <p>FOLLOW-ON MAINTENANCE</p> <p>Do final inspection (para 5-2).</p>	

4-3. DECAL REMOVAL AND REPLACEMENT (CONT)

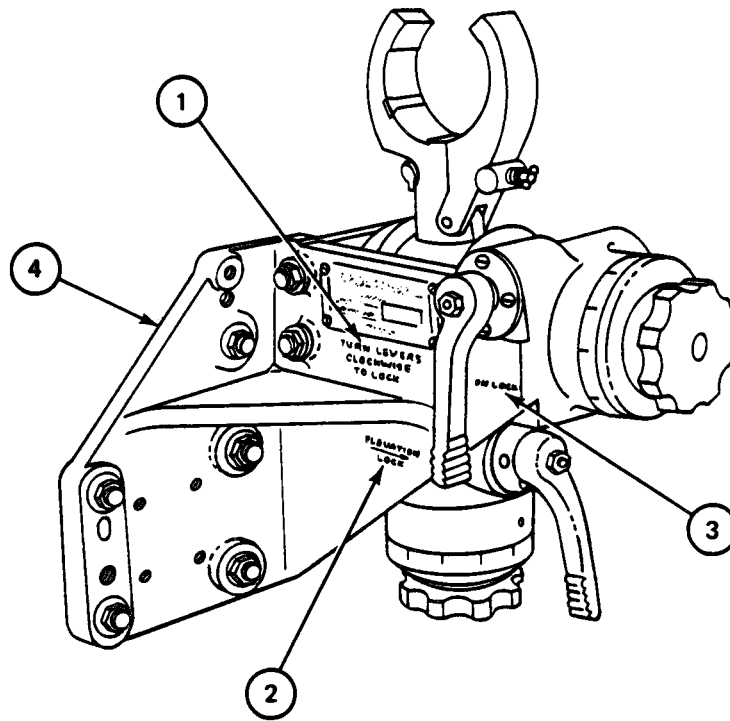

Section 3. TELESCOPE MOUNT

4-4. TELESCOPE MOUNT MAINTENANCE PROCEDURES INDEX

Task	Reference (para)
Removal	4-5
Installation	4-6

4-5. TELESCOPE MOUNT REMOVAL

TOOLS: 3/4" socket
 3/ 8" square drive ratchet
 Slip joint pliers
 5/ 16" open end wrench

PERSONNEL: Two

EQUIPMENT CONDITION: Telescope mount mounted in vehicle
 TM 20-2 for removing telescope (TM 9-2350-215 -20-2 for M60A1,
 TM 9-2350-257-20-2 for M60A1 Rise, TM 9-2350-260 -20-2 for M60,
 TM 9-2350-222-20-2 for M728, and TM 9-2350-258-20-2 for M48A5).
 TM 10 for securing gun in travel lock position (TM 9-2350-215-10
 for M60A1, TM 9-2350-257-10 for M60A1 Rise, TM 9-2350-260-10
 for M60, TM 9-2350-222-10 for M728 and TM 9-2350-258-10 for M48A5).

WARNING

Two people are needed to remove telescope mount. If telescope mount falls, equipment damage and injury to personnel may result.

FRAME 1	
Step	Procedure
	NOTE
	Do steps 1 thru 3 for M60 tank only.
1.	(Repairman A) Loosen wingnut (1) of loop clamp assembly (2) and remove instrument light.
2.	(Repairman A) Using wrench, remove four screws (3) and four lockwashers (4) and remove loop clamp assembly (2) from telescope mount (5).

4-5. TELESCOPE MOUNT REMOVAL (CONT)

Step	Procedure
3.	(Repairman A) Install instrument light into loop clamp assembly (2) and tighten wingnut (1).
4.	(Repairman B) Using socket and square drive ratchet, remove five mounting screws (6), five lockwashers (7) and five flat washers (8) joining telescope mount (5) to recoil mechanism housing (9).
GO TO FRAME 2	

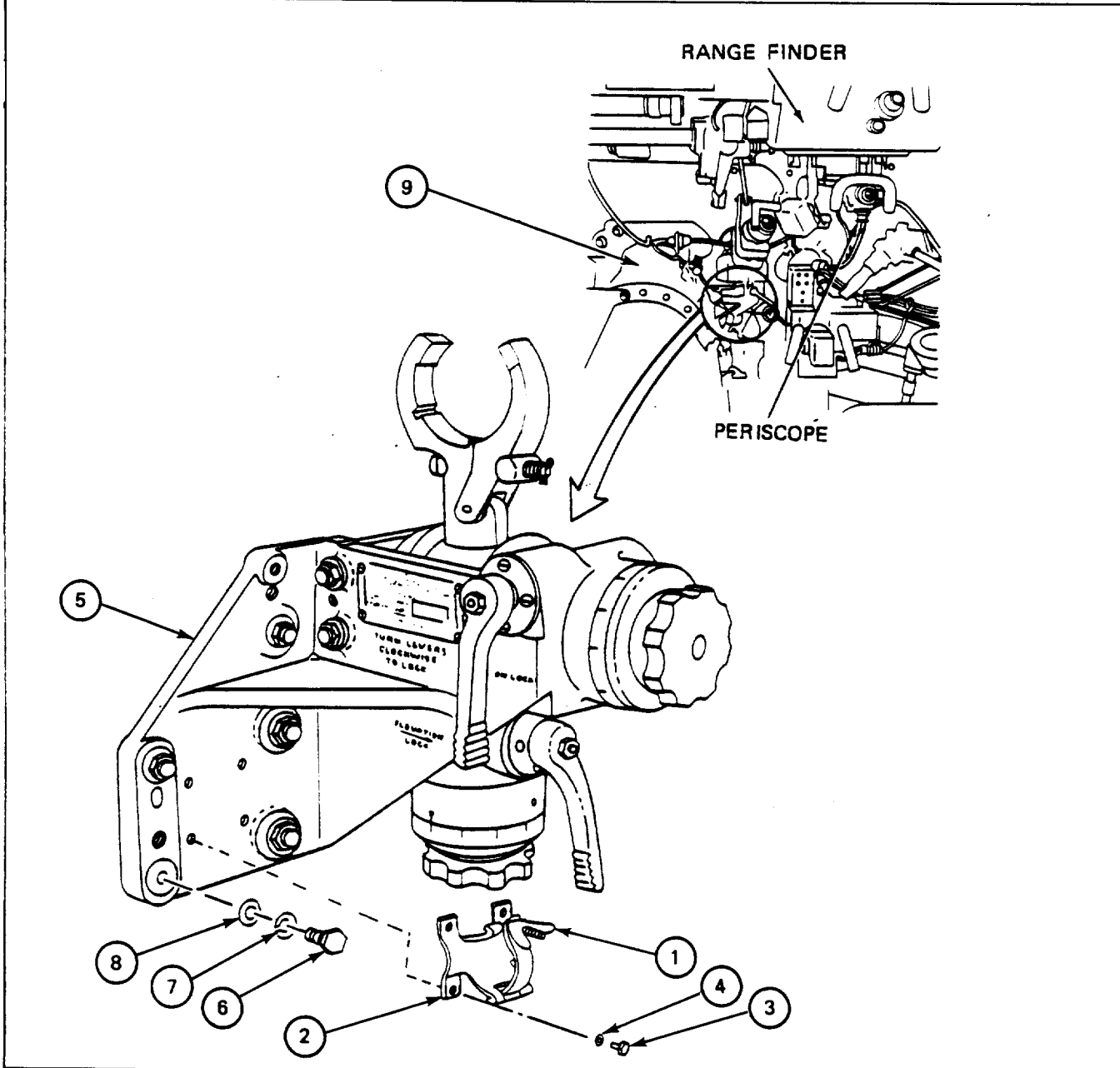

4-5. TELESCOPE MOUNT REMOVAL (CONT)

FRAME 2	
Step	Procedure
1.	(Repairman B) Using two mounting screws (1) from telescope mount (2) as jackscrews, insert mounting screws (1) into jackscrew holes (3).
2.	(Repairman A) Hold telescope mount (2).
NOTE	
Telescope mount (2) will move toward you and off of locator pins (4) as mounting screws (1) are tightened.	
3.	(Repairman B) Using socket and square drive ratchet, tighten mounting screws (1) until telescope mount (2) is clear of locating pins (4).
4.	(Repairman A) Remove telescope mount (2).
5.	(Repairman B) Using socket and square drive ratchet, remove two mounting screws (1).
NOTE	
Remove locating pins (4) only if they need to be replaced.	
6.	(Repairman B) Using slip joint pliers, remove two locating pins (4) from recoil mechanism housing in vehicle.
END OF TASK	

4-5. TELESCOPE MOUNT REMOVAL (CONT)

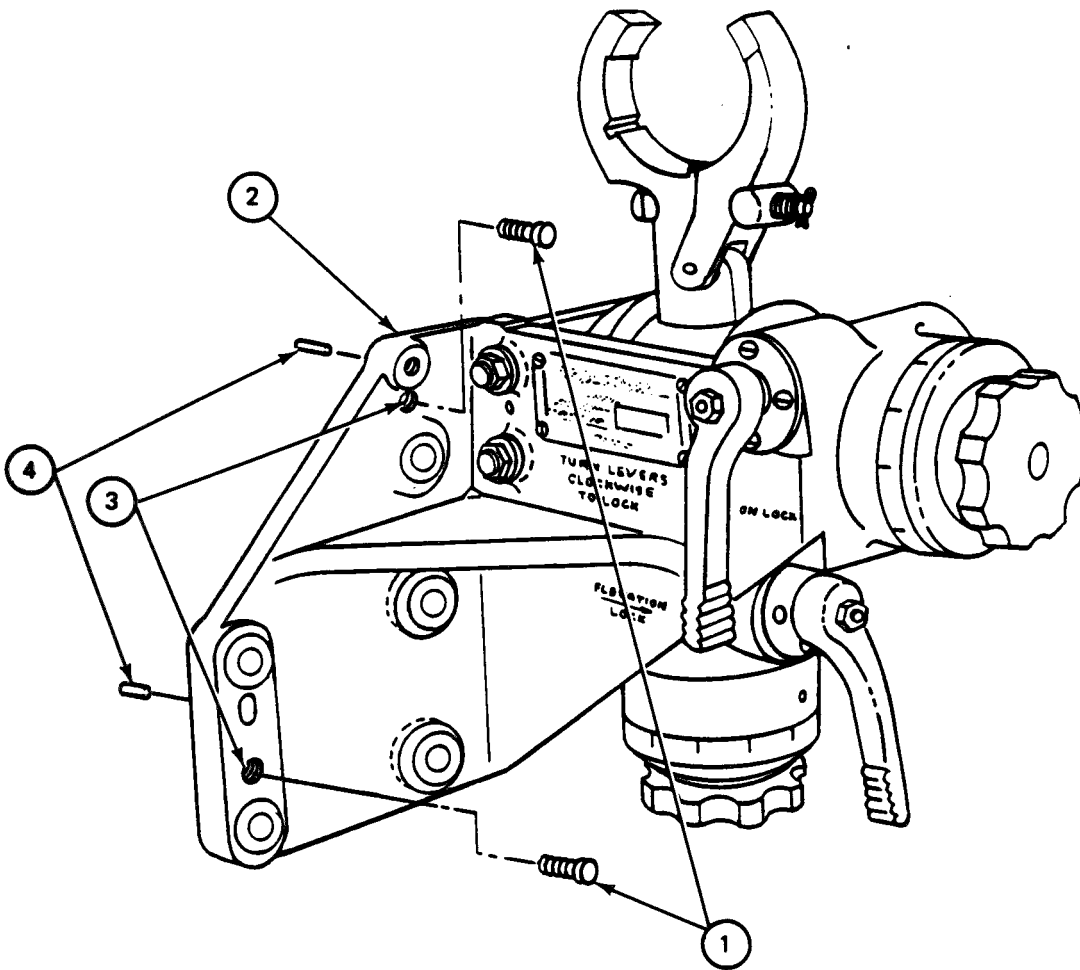

4-6. TELESCOPE MOUNT INSTALLATION

TOOLS: Soft face hammer
 3/4" socket
 3/8" square drive ratchet
 5/ 16" open end wrench

PERSONNEL: Two

EQUIPMENT CONDITION: Telescope mount ready to be mounted in tank

FRAME 1	
Step	Procedure
	NOTE
1.	<p style="text-align: center;">Do the next step only if locating pins have been removed from recoil mechanism housing in the vehicle.</p> <p>(Repairman A) Using soft face hammer, drive two locating pins (1) into holes on recoil mechanism housing.</p>
	<div style="border: 1px solid black; padding: 5px; width: fit-content; margin: 0 auto;">WARNING</div>
	<p>Two repairmen are needed to install telescope mount (2). If telescope mount (2) falls, equipment damage and injury to personnel may result.</p>
2.	(Repairman A and B) Place telescope mount (2) on recoil mechanism housing so that locating pin holes (3) are lined up with locating pins (1).
3.	(Repairman A) Hold telescope mount (2).
4.	(Repairman B) Using socket and ratchet, install five flat washers (4), five lockwashers (5) and five screws (6).
	GO TO FRAME 2

4-6. TELESCOPE MOUNT INSTALLATION (CONT)

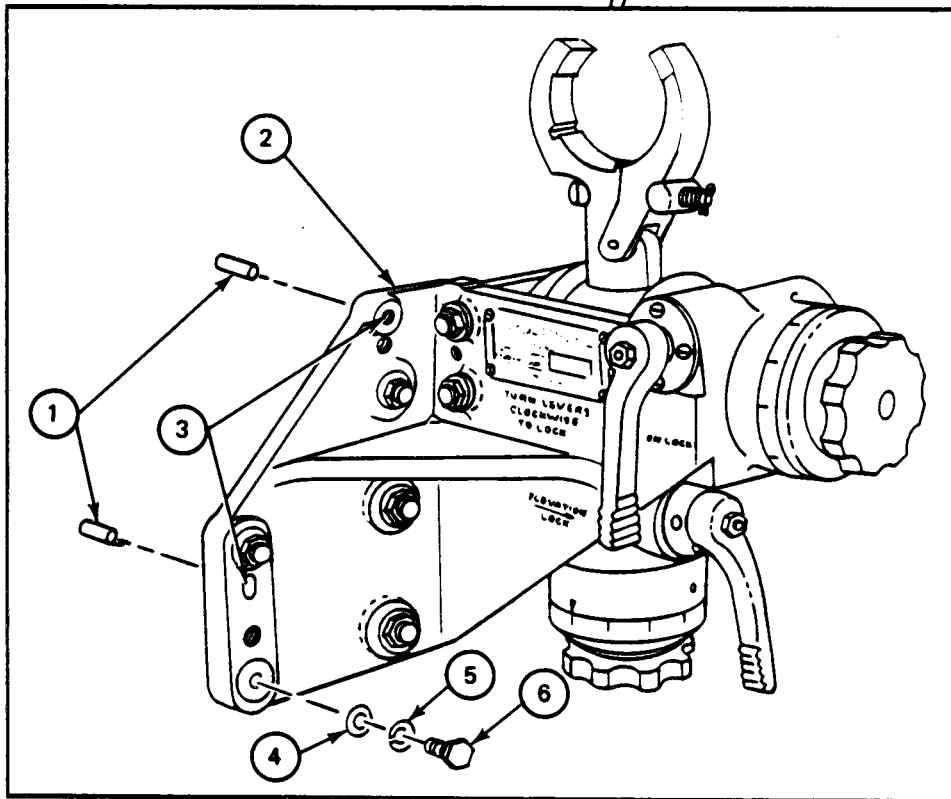
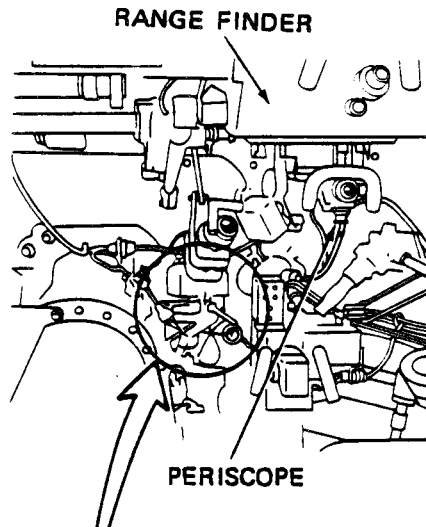

4-6. TELESCOPE MOUNT INSTALLATION (CONT)

Frame 2	
Step	Procedure
	<p>NOTE</p> <p>Do steps 1 thru 4 for M60 tank only.</p>
1.	(Repairman A) Loosen wing nut (1) of loop clamp assembly (2) and remove instrument light.
2.	(Repairman A) Place loop clamp assembly (2) against housing (3).
3.	(Repairman A) Using wrench, install four lockwashers (4) and four screws (5).
4.	(Repairman A) Install instrument light into loop clamp assembly (2) and tighten wing nut (1).
	END OF TASK

4-6. TELESCOPE MOUNT INSTALLATION (CONT)

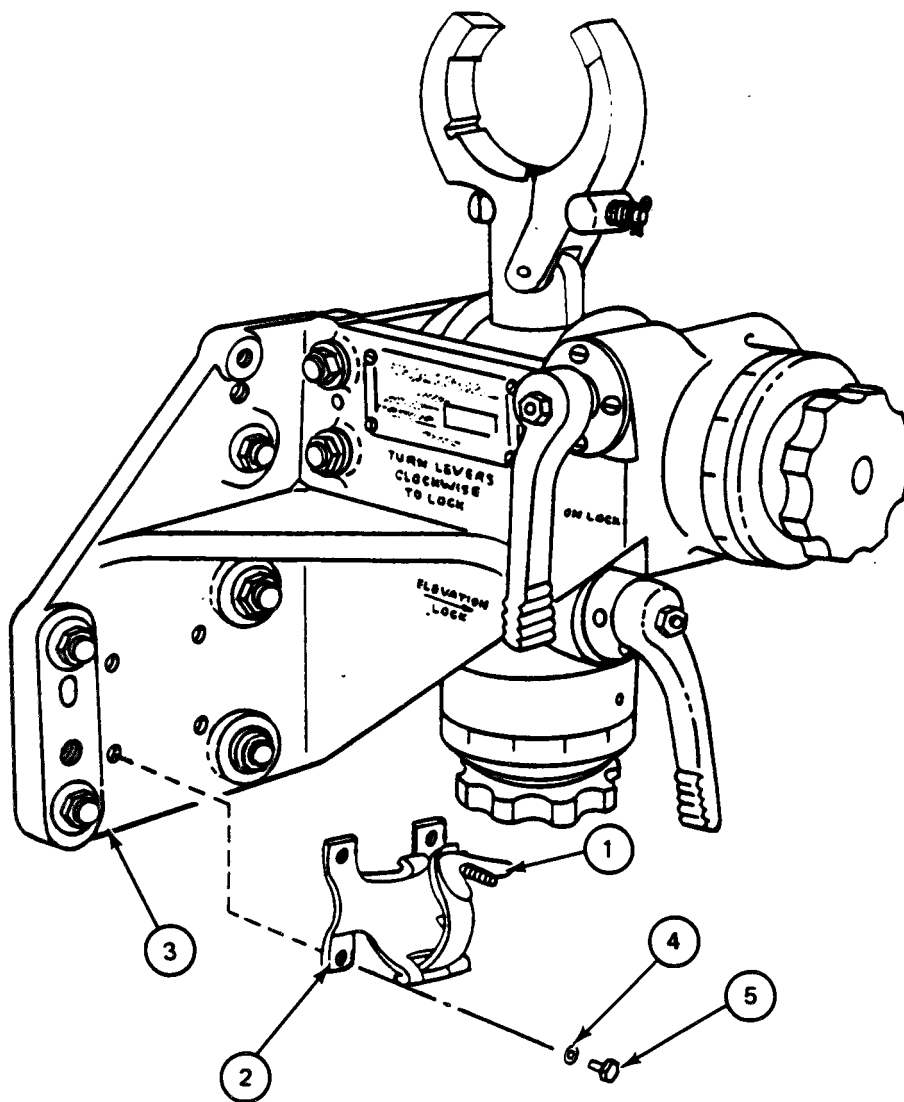

Section 4. DEFLECTION AND ELEVATION LOCKING MECHANISMS

4-7. DEFLECTION AND ELEVATION LOCKING MECHANISMS MAINTENANCE PROCEDURES INDEX

Task	Reference (para)
Disassembly	4-8
Assembly	4-9

4-8. DEFLECTION AND ELEVATION LOCKING MECHANISMS DISASSEMBLY

TOOLS: 7/16" open end wrench
 3/8" and 1/4" flat tip screwdriver
 1/4" brass drift pin
 4 oz. ball peen hammer
 6" adjustable wrench

PERSONNEL: One

EQUIPMENT CONDITION: Telescope mount on work bench

FRAME 1	
Step	Procedure
	<p style="text-align: center;">NOTE</p> <p style="text-align: center;">The disassembly procedure for both deflection and elevation locking mechanisms are the same.</p> <p style="text-align: center;">NOTE</p> <p style="text-align: center;">Lock lever (2) must be in unlocked position.</p> <ol style="list-style-type: none"> 1. Using open end wrench, remove nut (1) and lock lever (2). 2. Using 1/4" flat tip screwdriver, remove four screws (3), four lockwashers (4) and cover (5). 3. Remove shaft (6) with stud (7), washer (8) and packing (9).

4-8 DEFLECTION AND ELEVATION LOCKING MECHANISMS DISASSEMBLY (CONT)

Step	Procedure
<p>NOTE</p> <p>Stud (7) has a left hand thread. To take off, turn stud (7) clockwise.</p> <p>4. Using adjustable wrench, unscrew shaft (6) from stud (7).</p> <p>5. Using 3/8" flat tip screwdriver, remove plug (10).</p> <p>6. Using hammer and drift pin, tap out wedge (11).</p> <p>END OF TASK</p>	

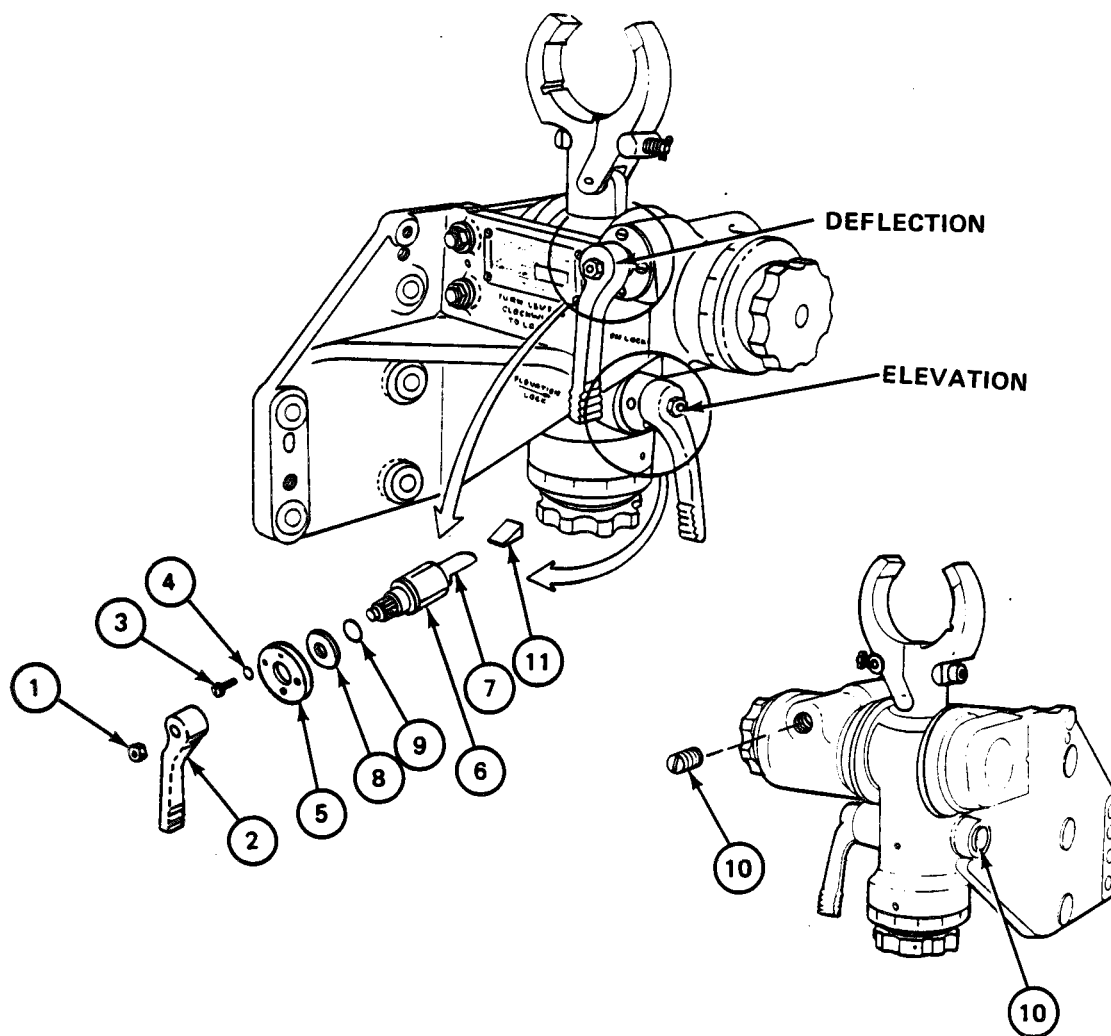

4-9. DEFLECTION AND ELEVATION LOCKING MECHANISMS ASSEMBLY

Tools: 3/8” and 1/4” flat tip screwdriver
 6” adjustable wrench
 7/16” open end wrench

SUPPLIES: Aircraft and instrument grease (item 2, App. A)
 Sealing compound (item 6, App. A)
 Pneumatic systems grease (item 3, App. A)

PERSONNEL: One

REFERENCES: JPG 4IC for lubricating

EQUIPMENT CONDITION: Telescope mount on work bench

NOTE

This maintenance procedure is used for both deflection locking mechanism and elevation locking mechanism.

FRAME 1	
Step	Procedure
1.	Put aircraft and instrument grease on wedge (1).
2.	Put wedge (1) into housing assembly (2) so that flat surface of wedge is resting on flat surface of slide assembly (3).
3.	Put plug (4) into housing assembly (2).
4.	Using 3/8” flat tip screwdriver, tighten plug (4) until it bottoms.
5.	Using adjustable wrench, screw stud (5) counterclockwise into shaft (6).
	GO TO FRAME 2

4-9. DEFLECTION AND ELEVATION LOCKING MECHANISMS ASSEMBLY
(CONT)

DEFLECTION LOCKING
MECHANISM ASSEMBLY

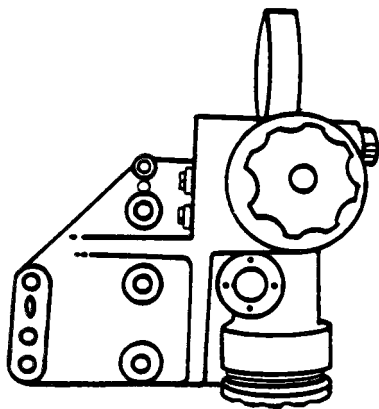
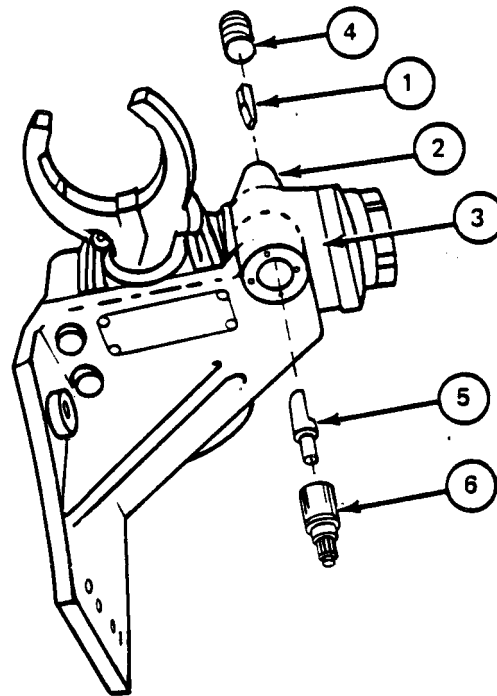

BENCH POSITION FOR
ELEVATION LOCKING
MECHANISM

4-9. DEFLECTION AND ELEVATION LOCKING MECHANISMS ASSEMBLY (CONT)

FRAME 2	
Step	Procedure
<ol style="list-style-type: none"> 1. 2. 3. 4. 5. 6. 7. 8. 	<p>Put aircraft and instrument grease on stud (1) and washer (2).</p> <p>Put pneumatic systems grease on packing (3).</p> <p>Put packing (3) and washer (2) on shaft of stud (1).</p> <p>Put stud (1) in housing assembly (4) with flat surface of stud (1) resting on flat surface of housing assembly (4).</p> <p>Using 1/4" flat tip screwdriver, install cover (5) with four screws (6) and four lockwashers (7).</p> <p>Put lock lever (8) on splined end of shaft (1). Turn lock lever (8) clockwise as far as it will go (you may have to repeat this step before the lever tightens so it will not move).</p> <p>Remove lock lever (8) from shaft (1) and put back so that handle of lock lever (8) is pointing down.</p> <p>Using open end wrench, install nut (9) on shaft (1).</p> <p style="text-align: center;">NOTE</p> <p style="text-align: center;">FOLLOW-ON MAINTENANCE</p> <p style="text-align: center;">Do checkout procedure (Vol I, para 2-2).</p> <p>END OF TASK</p>

4-9. DEFLECTION AND ELEVATION LOCKING MECHANISMS ASSEMBLY
(CONT)

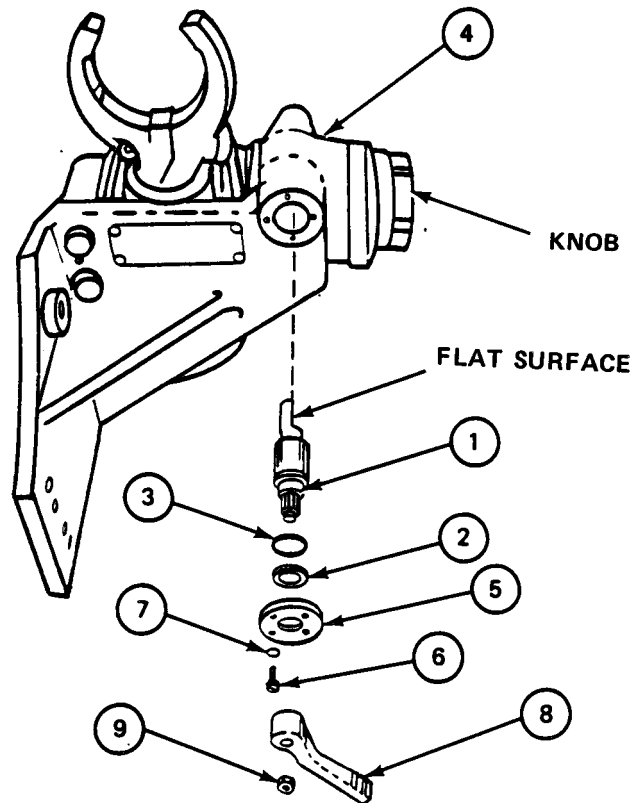

Section 5. ELEVATION BORESIGHT ADJUSTING MECHANISM

4-10. ELEVATION BORESIGHT ADJUSTING MECHANISM MAINTENANCE PROCEDURES INDEX

Task	Reference (para)
Disassembly Assembly	4-11 4-12

4-11. ELEVATION BORESIGHT ADJUSTING MECHANISM DISASSEMBLY

TOOLS: Adjustable face spanner wrench, 0.177" to 0.187" pin diameter
 4 oz. ball peen hammer
 3/32" drive pin punch
 3/32" socket head screw key (Allen wrench or equivalent)

PERSONNEL: One

EQUIPMENT CONDITION: Telescope mount on work bench

FRAME 1	
Step	Procedure
	<p style="text-align: center;">NOTE</p> <p style="text-align: center;">Pin (1) is tapered and can be removed only one way.</p> <ol style="list-style-type: none"> 1. Using punch and hammer, drive out pin (1) from elevation boresight knob (2). 2. Using Allen wrench, remove setscrew (3). 3. Remove elevation boresight knob (2) with spring (not shown) and scale dial (4) still joined. <p>GO TO FRAME 2</p>

4-11. ELEVATION BORESIGHT ADJUSTING MECHANISM DISASSEMBLY (CONT)

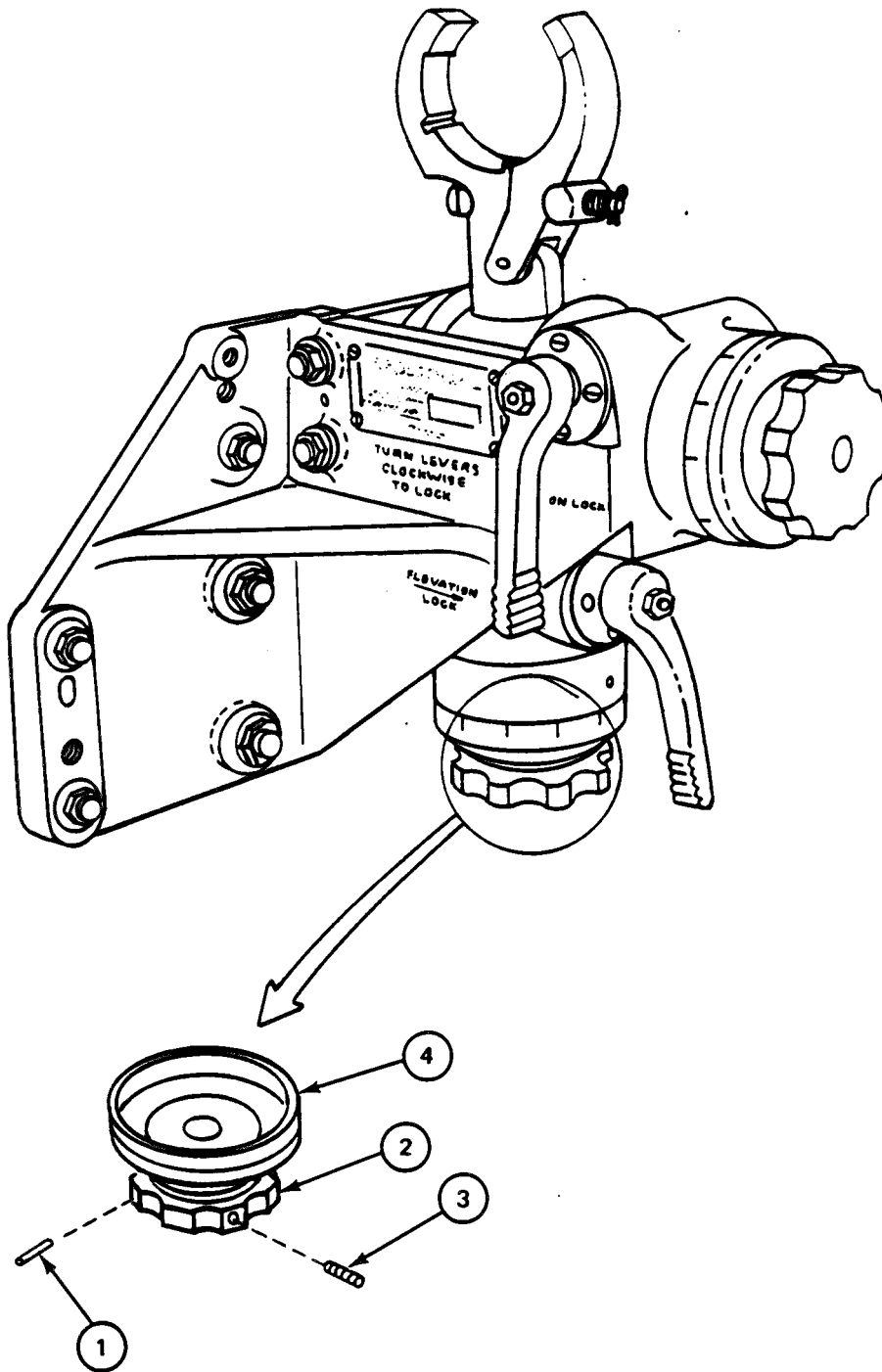

4-11. ELEVATION BORESIGHT ADJUSTING MECHANISM DISASSEMBLY (CONT)

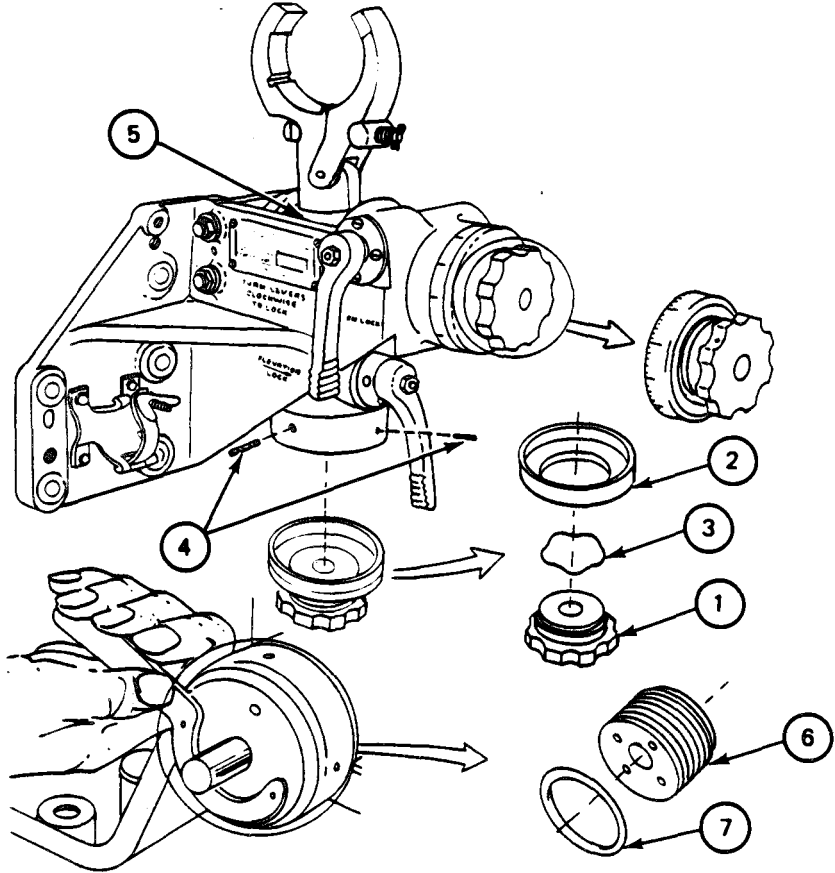
FRAME 2	
Step	Procedure
	<div style="text-align: center; border: 1px solid black; padding: 5px; width: fit-content; margin: 0 auto;"> CAUTION </div> <p style="text-align: center;">Hold knob (1) and scale dial (2) so that spring (3) cannot fly loose when you pull knob and scale dial apart.</p> <ol style="list-style-type: none"> 1. Pull knob (1) from scale dial (2) to free spring (3). 2. Using Allen wrench, remove two setscrews (4) from slide assembly (5). 3. Using spanner wrench, remove ring (6) with packing (7) still joined from slide assembly (5). 4. Remove packing (7) from ring (6). <p>GO TO FRAME 3</p>
	

4-11. ELEVATION BORESIGHT ADJUSTING MECHANISM DISASSEMBLY (CONT)

FRAME 3		
Step	Procedure	
1.	Remove bearing (1) and flat washer (2) from ring (3).	
2.	Turn special screw (4) counterclockwise and remove.	
3.	Remove packing (5) from screw special (4).	
4.	Remove bearing (6) and flat washer (7) from slide assembly (8).	
END OF TASK		

4-12. ELEVATION BORESIGHT ADJUSTING MECHANISM ASSEMBLY

TOOLS: Adjustable face spanner wrench, 0.177" to 0.187" pin diameter
 Spring wrench (App. C)
 4 oz. ball peen hammer
 3/32" socket head screw key (Allen wrench or equivalent)

SUPPLIES: Aircraft and instrument grease (item 2, App. A)
 Sealing compound (item 6, App. A)
 Pneumatic systems grease (item 3, App. A)

PERSONNEL: One

REFERENCES: JPG 41C for: Lubricating
 Putting on sealing compound

EQUIPMENT CONDITION: Telescope mount on work bench

FRAME 1	
Step	Procedure
1.	Put aircraft and instrument grease on thick flat washer (1) (JPG). Install washer (1) in housing (2).
2.	Put aircraft and instrument grease on bearing (3) (JPG). Place bearing (3) against washer (1).
3.	Put pneumatic systems grease on packing (4) and special screw (5) (JPG). Place packing (4) on special screw.
4.	Install special screw (5) in housing (2).
5.	Put aircraft and instrument grease on bearing (6) (JPG). Install bearing (6) on special screw (5).
6.	Put aircraft and instrument grease on flat washer (7) (JPG). Place washer (7) against bearing (6).
7.	Put pneumatic systems grease on packing (8) and ring (9) (JPG). Install packing (8) on ring (9).
NOTE	
Washers (1) and (7) and bearings (3) and (6) must be centered in housing (2) to allow ring (9) to screw in. Packing (8) must be inside housing (2) when ring (9) is tight.	
8.	Using spanner wrench, screw ring (9) into housing (2) until ring (9) is tight.

4-12. ELEVATION BORESIGHT ADJUSTING MECHANISM ASSEMBLY (CONT)

Step	Procedure
9.	Using spanner wrench, loosen ring (9) 1/4 turn.
10.	Put sealing compound on two setscrews (10) (JPG). Using Allen wrench, screw in two setscrews (10). GO TO FRAME 2

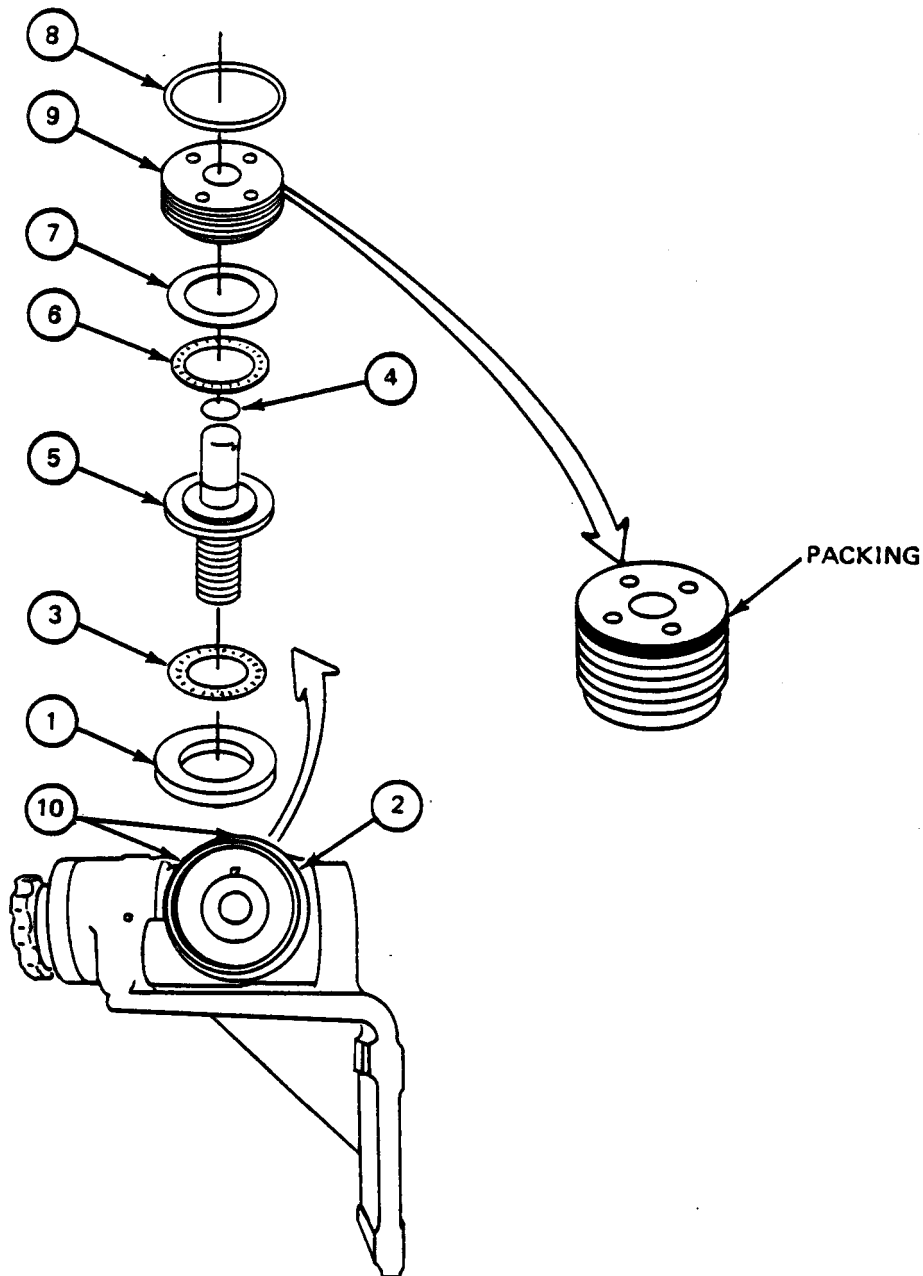

4-12. ELEVATION BORESIGHT ADJUSTING MECHANISM ASSEMBLY (CONT)

FRAME 2	
Step	Procedure
<ol style="list-style-type: none"> 1. 2. 3. 	<p>Using spring wrench, fit spring (1) in groove of knob (2). Put knob (2) with spring (1) into scale dial (3) Place knob (2) with scale dial (3) so that hole in knob (2) lines up with hole in shaft (4).</p>
<p>NOTE</p>	
<p>Pin (5) is tapered and can be installed only one way.</p>	
<ol style="list-style-type: none"> 4. 5. 	<p>Put pin (5) through hole in knob (2) and shaft (4). Using Allen wrench, screw setscrew (6) into knob (2).</p>
<p>NOTE</p>	
<p>FOLLOW-ON MAINTENANCE</p>	
<p>Do checkout procedure (Vol I, para 2-2).</p>	
<p>END OF TASK</p>	

4-12. ELEVATION BORESIGHT ADJUSTING MECHANISM ASSEMBLY (CONT)

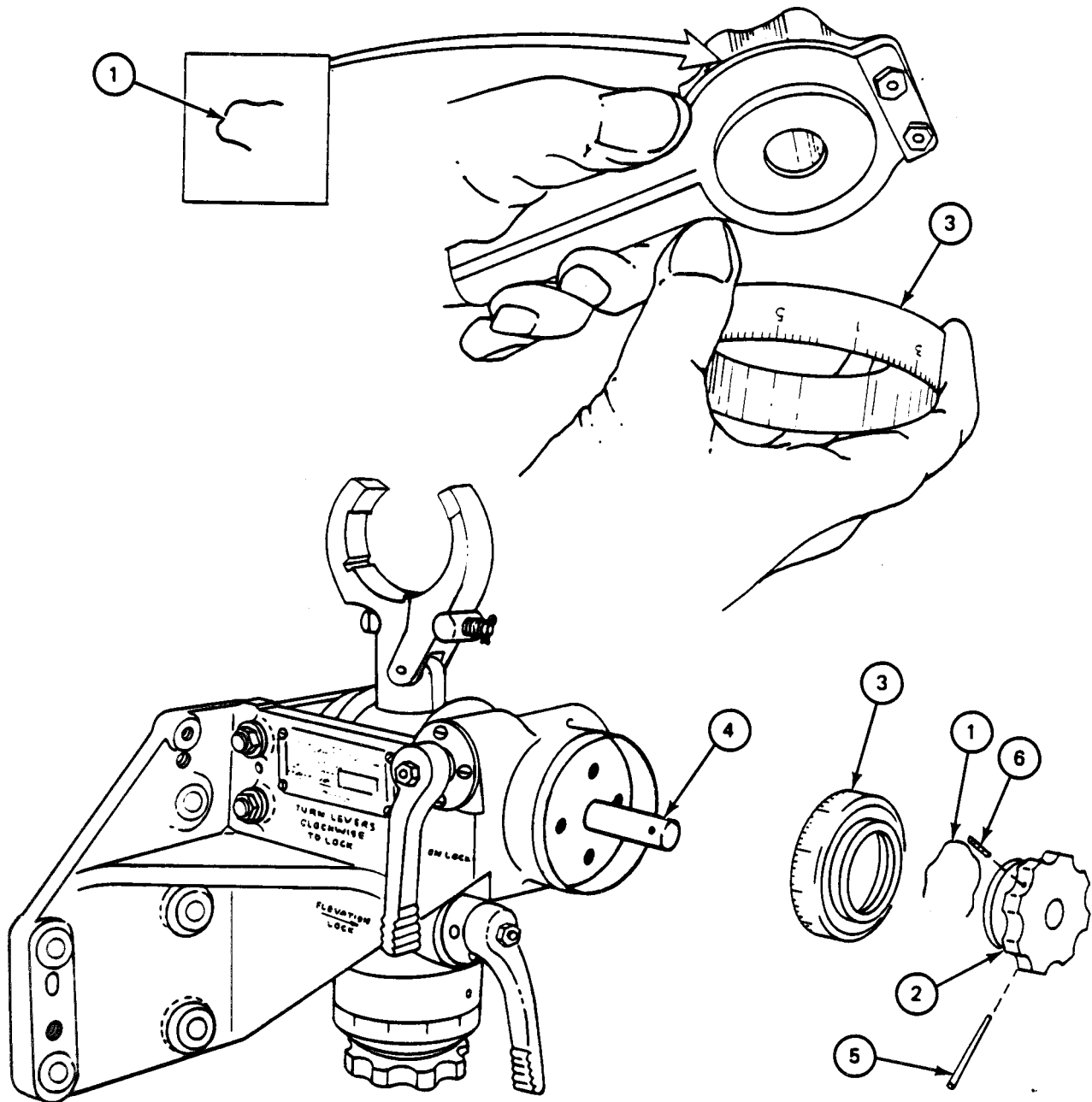

Section 6. DEFLECTION BORESIGHT ADJUSTING MECHANISM

4-13. DEFLECTION BORESIGHT ADJUSTING MECHANISM MAINTENANCE PROCEDURES INDEX

Task	Reference (para)
Disassembly	4-14
Assembly	4-15

4-14. DEFLECTION BORESIGHT ADJUSTING MECHANISM DISASSEMBLY

Tools: Adjustable face spanner wrench, 0.177" to 0.187" pin diameter
 4 oz. ball peen hammer
 3/32" drive pin punch
 3/32" socket head screw key (Allen wrench or equivalent)

PERSONNEL: One

EQUIPMENT CONDITION: Telescope mount on work bench

FRAME 1	
Step	Procedure
1.	NOTE
	Pin (1) is tapered and can be removed only one way.
1.	Using punch and hammer, drive out pin (1) from boresight knob (2).
2.	Using Allen wrench, remove setscrew (3).
3.	NOTE
	Carefully remove knob and scale together.
	Remove boresight knob (2). GO TO FRAME 2

4-14. DEFLECTION BORESIGHT ADJUSTING MECHANISM DISASSEMBLY
(CONT)

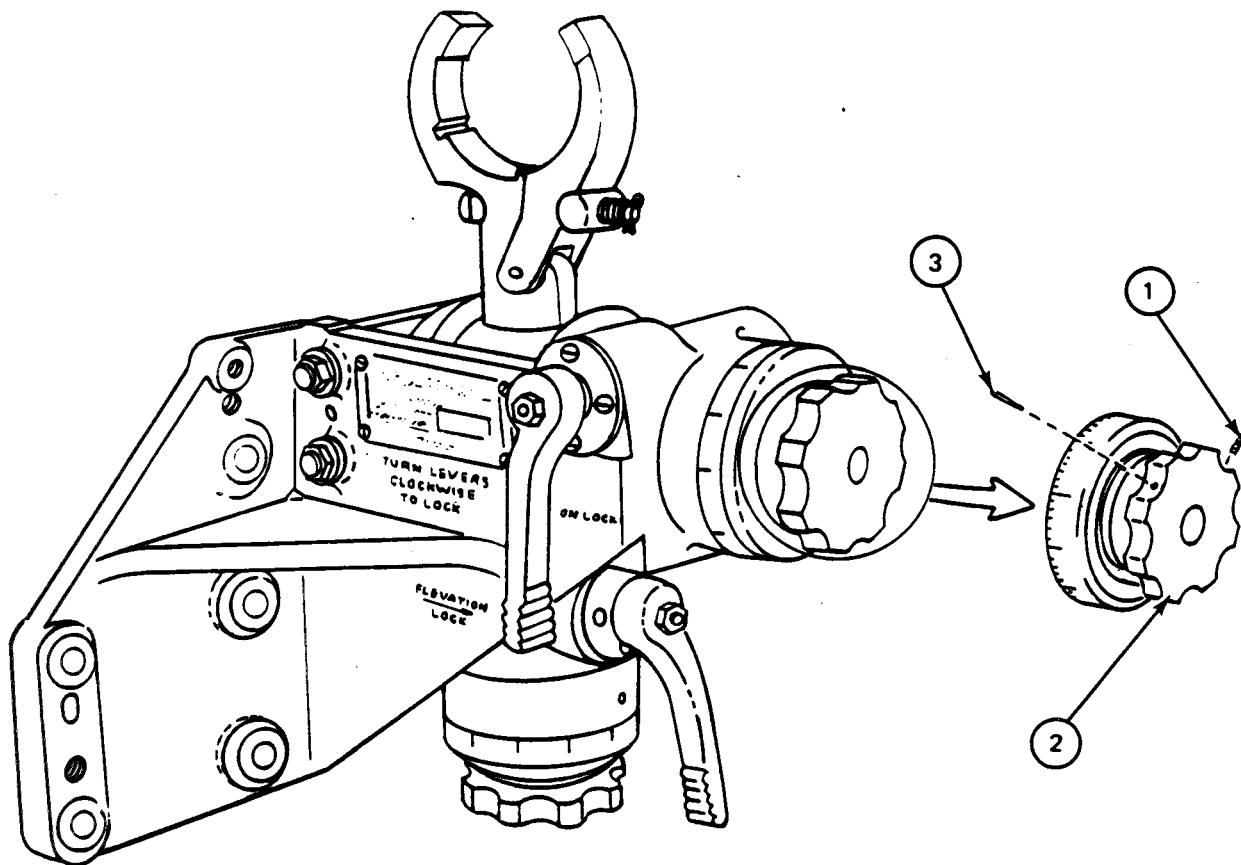

4-14. DEFLECTION BORESIGHT ADJUSTING MECHANISM DISASSEMBLY (CONT)

FRAME 2	Step Procedure
	<p style="text-align: center;">CAUTION</p> <p style="text-align: center;">Hold knob (1) and scale dial (2) so that spring (3) cannot fly loose when you pull knob (1) and scale dial (2) apart.</p> <ol style="list-style-type: none"> 1. Pull knob (1) from scale dial (2) to free spring (3). 2. Using Allen wrench, remove two setscrews (4) from housing (5). 3. Using spanner wrench, remove ring (6) with packing (7) still joined. 4. Remove packing (7) from ring (6). <p>GO TO FRAME 3</p>

4-14. DEFLECTION BORESIGHT ADJUSTING MECHANISM DISASSEMBLY
(CONT)

FRAME 3	
Step	Procedure
1.	Remove bearing (1) and flat washer (2) from ring (3).
2.	Turn special screw (4) counterclockwise and remove.
3.	Remove packing (5) from special screw (4).
4.	Remove bearing (6) and flat washer (7) from slide assembly (8).
	END OF TASK

The diagram illustrates the disassembly process. On the left, a perspective view of the mechanism is shown with a handle and a lens. An exploded view to the right shows the following components and their removal steps:

- Component 1:** A bearing being removed from the inner side of ring (3).
- Component 2:** A flat washer being removed from the inner side of ring (3).
- Component 3:** A ring with a central hole, from which components 1 and 2 are being removed.
- Component 4:** A special screw being turned counterclockwise, as indicated by a curved arrow.
- Component 5:** Packing material being removed from the end of the special screw (4).
- Component 6:** A bearing being removed from the inner side of the slide assembly (8).
- Component 7:** A flat washer being removed from the inner side of the slide assembly (8).
- Component 8:** The main slide assembly, which includes the handle and lens mechanism.

4-15. DEFLECTION BORESIGHT ADJUSTING MECHANISM ASSEMBLY

TOOLS: Adjustable face spanner wrench, 0.177” to 0.187” pin diameter
 Spring wrench (App. C)
 4 oz. ball peen hammer
 3/32” socket head screw key (Allen wrench or equivalent)

SUPPLIES: Aircraft and instrument grease (item 2, App. A)
 Sealing compound (item 6, App. A)
 Pneumatic systems grease (item 3, App. A)

PERSONNEL: One

REFERENCES: JPG 41 C for: Lubricating
 Putting on sealing compound

EQUIPMENT CONDITION: Telescope mount on work bench

FRAME 1	
Step	Procedure
1.	Put aircraft and instrument grease on thick flat washer (1) (JPG). Install washer (1) in housing (2).
2.	Put aircraft and instrument grease on bearing (3) (JPG). Place bearing (3) against washer (1).
3.	Put pneumatic systems grease on packing (4) and special screw (5) (JPG). Place packing (4) on special screw (5).
4.	Install special screw (5) in housing (2),
5.	Put aircraft and instrument grease on bearing (6) (JPG). Install bearing (6) on special screw (5).
6.	Put aircraft and instrument grease on flat washer (7) (JPG). Place washer (7) against bearing (6).
7.	Put pneumatic systems grease on packing (8) and ring (9) (JPG). Install packing (8) on ring (9).
NOTE	
Washers (1) and (7) and bearings (3) and (6) must be centered in housing (2) to allow ring (9) to screw in. Packing (8) must be inside housing (2) when ring (9) is tight.	
8.	Using spanner wrench, screw ring (9) into housing (2) until ring (9) is tight.

4-15. DEFLECTION BORESIGHT ADJUSTING MECHANISM ASSEMBLY (CONT)

Step	Procedure
9.	Using spanner wrench, loosen ring (9) 1/4 turn.
10.	Put sealing compound on two setscrews (10) (JPG). Using Allen wrench, screw in two setscrews (10). GO TO FRAME 2

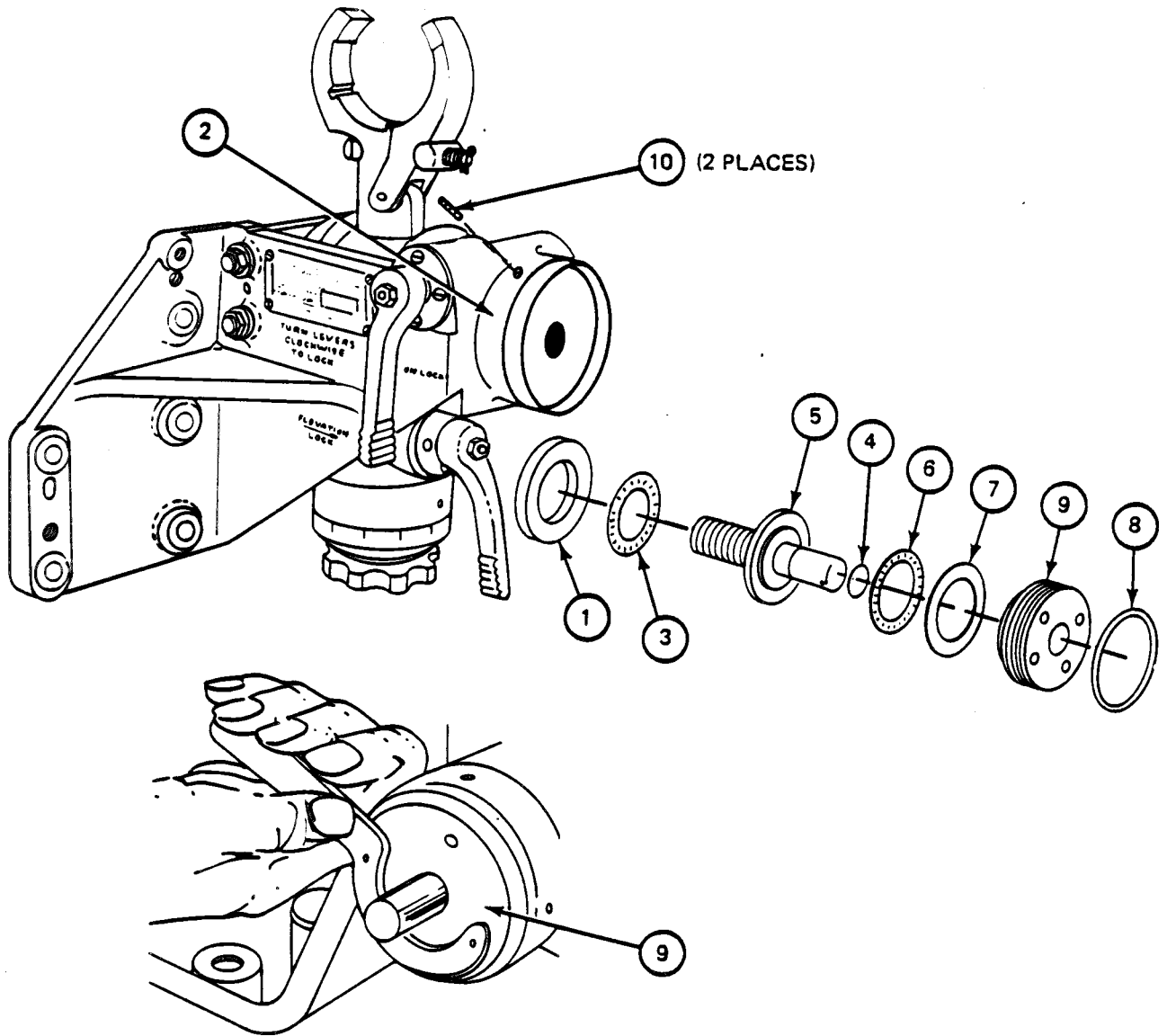

4-15. DEFLECTION BORESIGHT ADJUSTING MECHANISM ASSEMBLY (CONT)

FRAME 2	
Step	Procedure
<ol style="list-style-type: none"> 1. 2. 3. 4. 5. 	<p>Using spring wrench, fit spring (1) in groove of knob (2).</p> <p>Install knob (2) with spring (1) into scale dial (3).</p> <p>Install knob (2) with scale dial (3) so that hole in knob (2) lines up with hole in shaft (4).</p> <p style="text-align: center;">NOTE</p> <p style="text-align: center;">Pin (5) is tapered and can be installed only one way.</p> <p>Place pin (5) through hole in knob (2) and shaft (4).</p> <p>Using Allen wrench, install setscrew (6) into knob (2).</p> <p style="text-align: center;">NOTE</p> <p style="text-align: center;">FOLLOW-ON MAINTENANCE</p> <p style="text-align: center;">Do checkout procedure (Vol I, para 2-2).</p> <p>END OF TASK</p>

4-15. DEFLECTION BORESIGHT ADJUSTING MECHANISM ASSEMBLY (CONT)

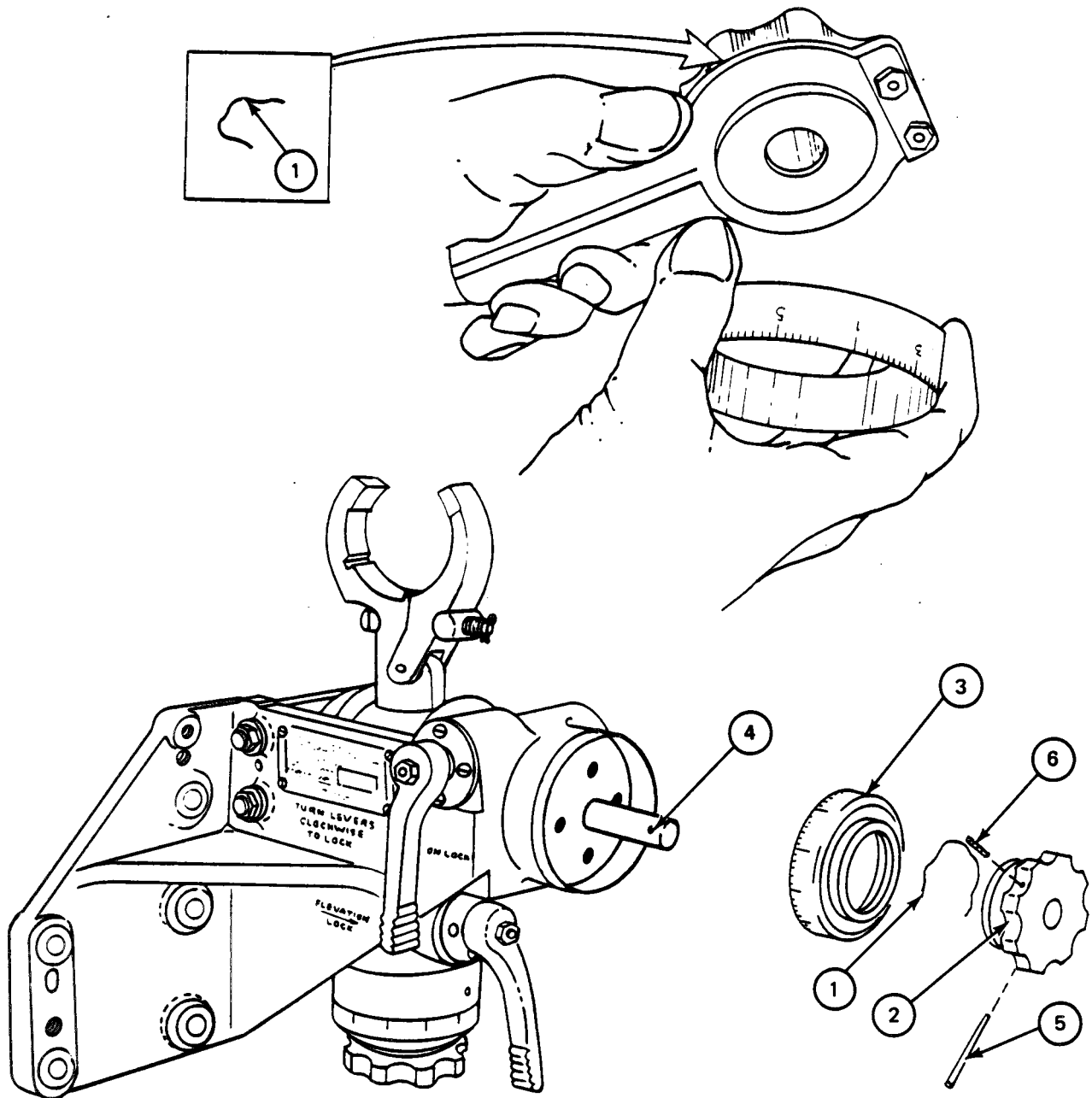

Section 7. HOLDER ASSEMBLY

4-16. HOLDER ASSEMBLY MAINTENANCE PROCEDURES INDEX

Task	Reference (para)
Removal	4-17
Disassembly	4-18
Assembly	4-19
Installation	4-20

4-17. HOLDER ASSEMBLY REMOVAL

TOOLS: 3/ 16” flat tip screwdriver

PERSONNEL: One

EQUIPMENT CONDITION: Telescope mount on work bench

PRELIMINARY PROCEDURES: Remove deflection and elevation locking mechanisms (para 4-8)
 Remove elevation boresight adjusting mechanism (para 4-11)

4-17. HOLDER ASSEMBLY REMOVAL (CONT)

FRAME 1	
Step	Procedure
1.	Remove holder assembly (1) with packing (2) attached.
2.	Remove packing (2) from holder assembly (1).
NOTE	
Key (3) will fall from bottom of slide assembly (4) when screw (5) and lockwasher (6) are removed.	
3.	Using screwdriver, remove screw (5), lockwasher (6) and key (3) from slide assembly (4).
END OF TASK	

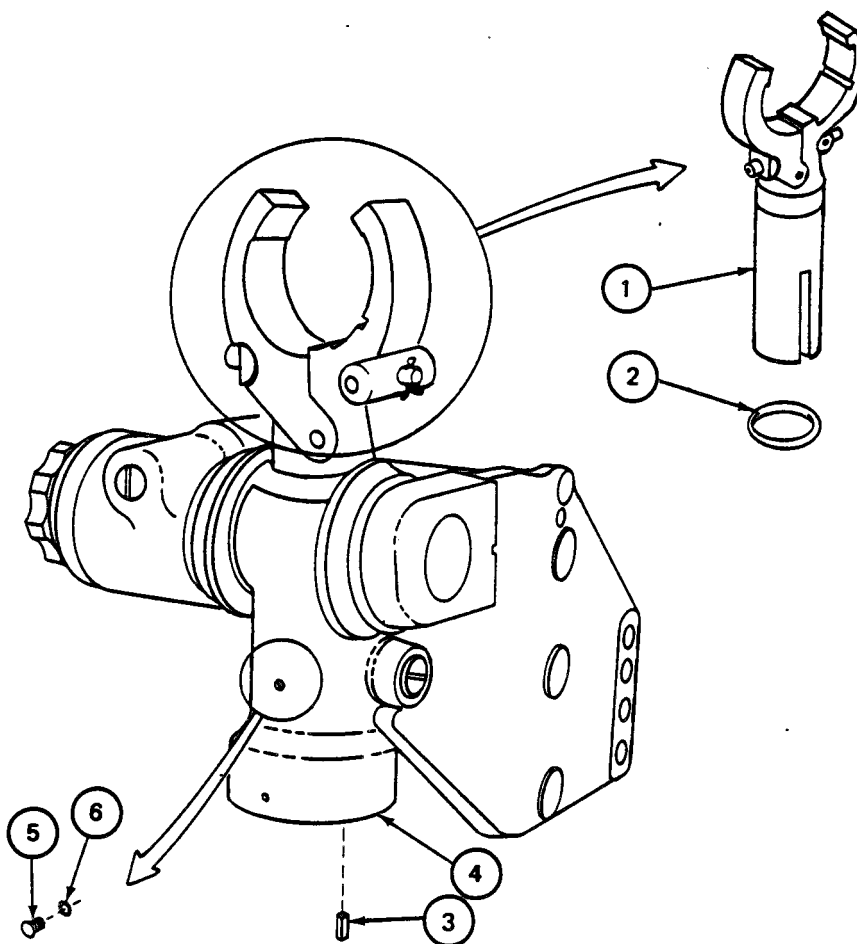

4-18. HOLDER ASSEMBLY DISASSEMBLY

TOOLS: Long nose pliers
4 oz. ball peen hammer
5/16" and 1/4" drive pin punch
1/8" and 5/16" socket head screw key (Allen wrench or equivalent)

PERSONNEL: One

EQUIPMENT CONDITION: Holder assembly on work bench

4-18. HOLDER ASSEMBLY DISASSEMBLY (CONT)

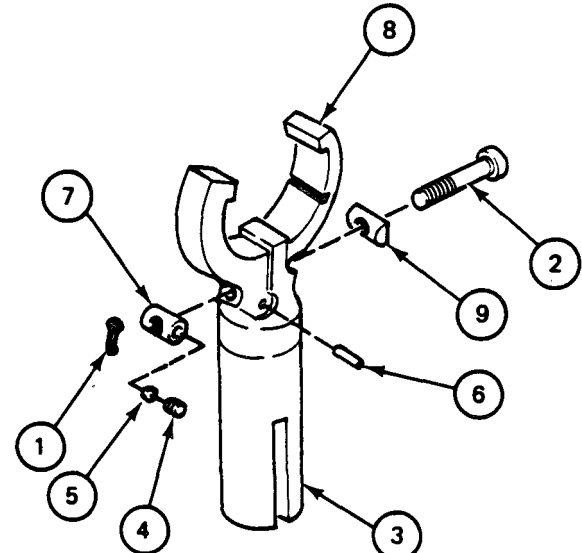
FRAME 1	
Step	Procedure
	<p style="text-align: center;">NOTE</p> <p style="text-align: center;">Some holder assemblies may have a spring pin instead of a cotter pin (1). Spring pin should be removed with a 5/16" punch.</p> <ol style="list-style-type: none"> 1. Using long nose pliers, remove cotter pin (1) from screw (2) on holder assembly (3). 2. Using 1/8" Allen wrench, remove setscrew (4) and plastic disk (5). 3. Using hammer and 1/4" punch, drive out pin (6). 4. Using 5/16" Allen wrench, remove screw (2), sleeve nut (7) and clamp (8). 5. Remove pivot (9) from screw (2). <p>END OF TASK</p>
	

4-19. HOLDER ASSEMBLY ASSEMBLY

TOOLS: Long nose pliers
 4 oz. ball peen hammer
 5/ 16“ and 1/8” socket head screw key (Allen wrench or equivalent)
 Center punch

PERSONNEL: One

REFERENCES: JPG 4IC for: Installing cotter pin
 Staking

EQUIPMENT CONDITION: Telescope mount on work bench

FRAME 1	
Step	Procedure
1.	Line up clamp (1) with holder (2).
2.	Using hammer, put pin (3) through clamp (1) and holder (2). Using hammer and center punch, stake both ends of pin (3) (JPG).
3.	Place pivot (4) on screw (5) and put screw (5) through clamp (1) and holder (2).
4.	Put sleeve nut (6) on screw (5). Make sure threaded hole of sleeve nut (6) is facing the flat surface of holder (2).
5.	Using 5/16” Allen wrench, tighten screw (5).
6.	Using 1/8” Allen wrench, install disk (7) and screw (8).
7.	Using long nose pliers, install cotter pin or spring pin (9) (JPG).
	END OF TASK

4-19. HOLDER ASSEMBLY ASSEMBLY (CONT)

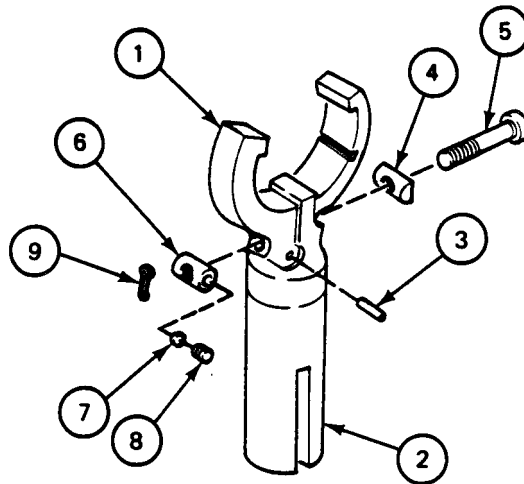

4-20. HOLDER ASSEMBLY INSTALLATION

TOOLS: 3/ 16“ flat tip screwdriver

SUPPLIES: Aircraft and instrument grease (item 2, App. A)
 Pneumatic systems grease (item 3, App. A)

PERSONNEL: One

REFERENCES: JPG 41C for lubricating

EQUIPMENT CONDITION: Telescope mount on work bench

FRAME 1	
Step»	Procedure
<ol style="list-style-type: none"> 1. 2. 3. 4. 	<p>Place key (1) in keyway of slide assembly (2).</p> <p>Using screwdriver, install screw (3) and lockwasher (4) to hold key (1).</p> <p>Put pneumatic systems grease on packing (5) and install on holder (6).</p> <p>Put a light coat of aircraft and instrument grease on holder (6). Put holder (6) in slide assembly (2) making sure keyway (7) is lined up with key (1).</p> <p style="text-align: center;">NOTE</p> <p style="text-align: center;">FOLLOW-ON MAINTENANCE</p> <p style="text-align: center;">Install elevation boresight adjusting mechanism (para 4-12). Install elevation and deflection locking mechanisms (para 4-9). Do checkout procedure (Vol I, para 2-2).</p> <p>END OF TASK</p>

4-20. HOLDER ASSEMBLY INSTALLATION (CONT)

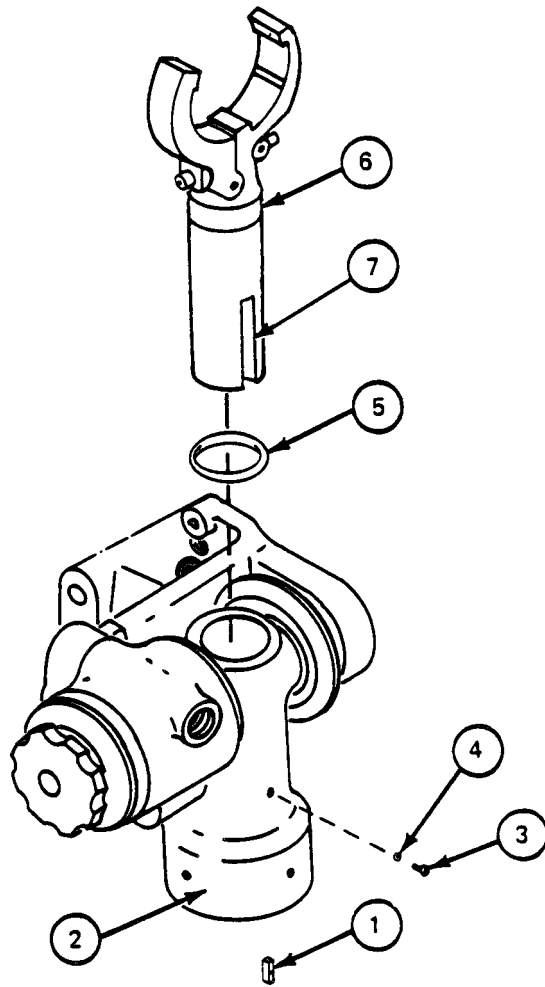

Section 8. SLIDE ASSEMBLY AND BOOTS

4-21. SLIDE ASSEMBLY AND BOOTS MAINTENANCE PROCEDURES INDEX

Task	Reference (para)
Removal Installation	4-22 4-23

4-22. SLIDE ASSEMBLY AND BOOTS REMOVAL

TOOLS: 9/ 16“ box wrench
 9/64" socket head screw key (Allen wrench or equivalent)
 9/ 16” flat tip screwdriver
 1/4” brass drift pin
 Soft face hammer
 4 oz. ball peen hammer
 Long nose pliers

PERSONNEL: One

EQUIPMENT CONDITION: Telescope mount on work bench

PRELIMINARY PROCEDURES: Remove deflection boresight adjusting mechanism (para 4- 14)
 Remove holder assembly (para 4- 17)

FRAME 1

Step	Procedure
1.	Using 9/ 16“ wrench, remove two screws (1), two lockwashers (2) and two flat washers (3) from side of telescope mount housing (4).
2.	Using ball peen hammer and drift pin, remove housing assembly (5) from slide assembly (6).
<p>NOTE</p> <p>All new type boots (7) and (11) with lacing wire (8) and grommets (9) are removed in the same way.</p> <p>If boot (7) is new type, go to step 3. If boot (7) is old type, go to step 5.</p>	
3.	Using long nose pliers, remove lacing wires (8).
4.	Remove four grommets (9).
5.	Carefully remove boot (7).

4-22. SLIDE ASSEMBLY AND BOOTS REMOVAL (CONT)

Step	Procedure
6.	Pull slide assembly (6) from housing (10).
7.	Remove boot (11) as in steps 3, 4, and 5.
8.	Using soft face hammer, remove plug (12) from housing assembly (5). GO TO FRAME 2

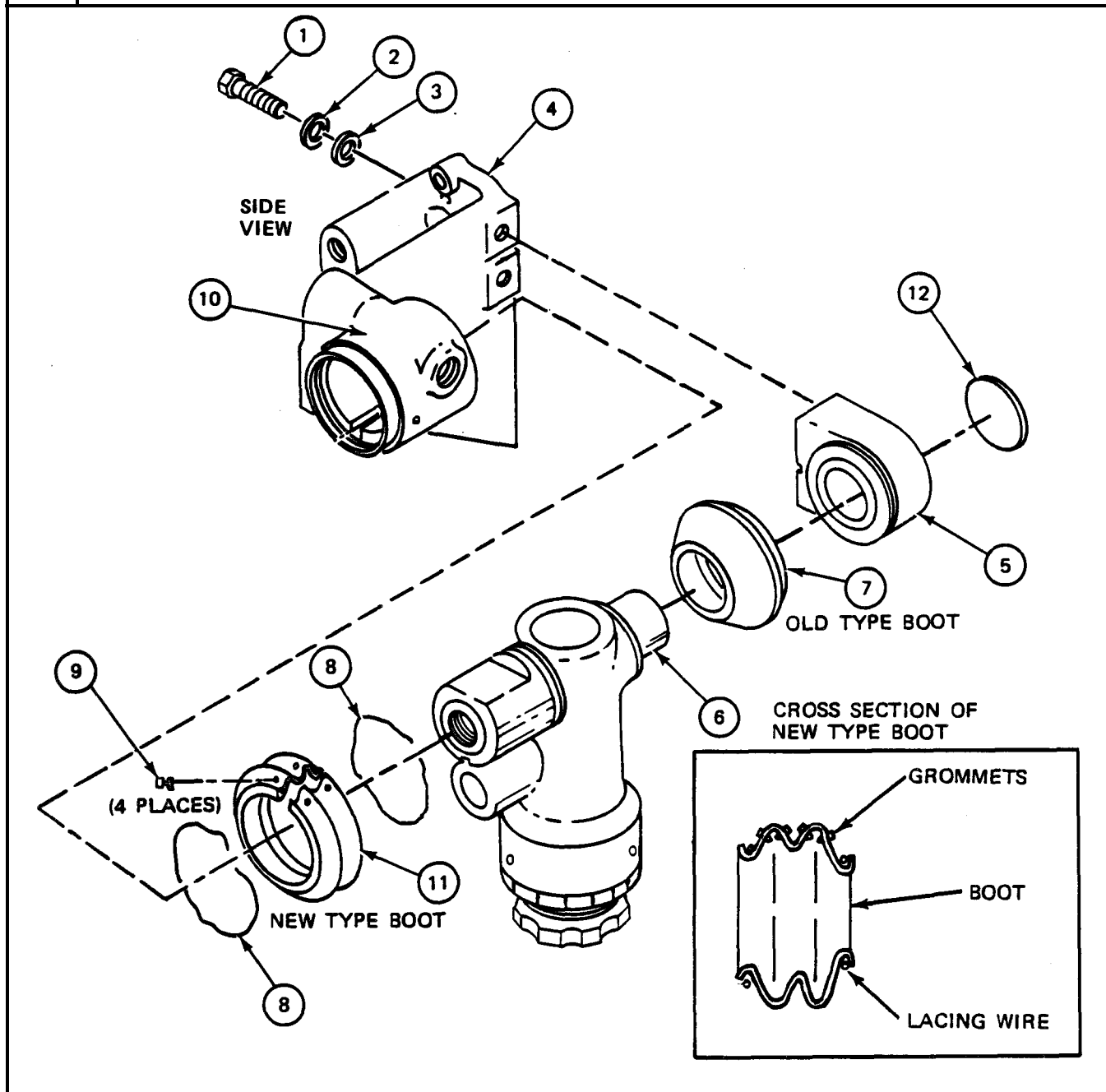

4-22. SLIDE ASSEMBLY AND BOOTS REMOVAL (CONT)

FRAME 2	
Step	Procedure
<ol style="list-style-type: none"> 1. 2. 3. <p>END OF TASK</p>	<p>Using screwdriver, remove six screws (1) and ring (2) from housing (3).</p> <p>Using Allen wrench, remove screw (4) and key (5).</p> <p>Using screwdriver, remove screw (6), lockwasher (7) and key (8).</p>

4-23. SLIDE ASSEMBLY AND BOOTS INSTALLATION

TOOLS: 5/64" socket head screw key (Allen wrench or equivalent)
 3/16" flat tip screwdriver
 9/16" box wrench
 Soft face hammer
 Long nose pliers

PERSONNEL: One

EQUIPMENT CONDITION: Telescope mount on work bench

FRAME 1	
Step	Procedure
<ol style="list-style-type: none"> 1. 2. 3. 4. 5. 6. 	<p>Place key (1) in keyway (2) of telescope mount housing (3).</p> <p>Using Allen wrench, install screw (4) to hold key (1) in place.</p> <p>Place key (5) in keyway (6) of telescope mount housing (3).</p> <p>Using screwdriver, install screw (7) and lockwasher (8) to hold key (5) in keyway (6).</p> <p>Place ring (9) against housing (10).</p> <p>Using screwdriver, install six screws (11) in ring (9).</p> <p>GO TO FRAME 2</p>

4-23. SLIDE ASSEMBLY AND BOOTS INSTALLATION (CONT)

FRAME 2	Step Procedure
	<p style="text-align: center;">NOTE</p> <p style="text-align: center;">If boot (1) is new type with lacing wire (2) and grommets (3), go to step 1. If boot (1) is old type, go to step 8.</p> <ol style="list-style-type: none"> 1. Put boot (1) on shaft of slide assembly (4). Put four grommets (3) on boot (1). 2. Put slide assembly (5) into housing (6) so that boot (1) is seated in groove in shaft of slide assembly (4) and groove in housing (6). 3. Using long nose pliers, put lacing wire (2) into boot (1). Make sure that boot (1) stays seated in grooves. 4. Put boot (7) on shaft of slide assembly (4). 5. Put four grommets (3) in boot (7). 6. Seat boot (7) in groove in shaft of slide assembly (4) and groove in housing assembly (8). 7. Using long nose pliers, put lacing wire (2) into boot (7). Make sure boot (7) stays seated in grooves. Go to step 11. 8. Put boot (1) on shaft (4) of slide assembly (5). 9. Put slide assembly (5) into housing (6) so that boot (1) is seated in groove in shaft (4) of slide assembly (5) and groove in housing (6). 10. Seat boot (7) in groove in shaft (4) of slide assembly (5) and groove in housing assembly (8). 11. Using 9/16" wrench, install two screws (9), two lockwashers (10) and two flat washers (11) to hold housing assembly (8) in place. 12. Using soft face hammer, tap plug (12) in housing assembly (8). <p style="text-align: center;">NOTE</p> <p style="text-align: center;">FOLLOW-ON MAINTENANCE</p> <p style="text-align: center;">Install deflection boresight adjusting mechanism (para 4-15). Install holder assembly (para 4-20). Do checkout procedure (Vol I, para 2-2).</p> <p>END OF TASK</p>

4-23. SLIDE ASSEMBLY AND BOOTS INSTALLATION (CONT)

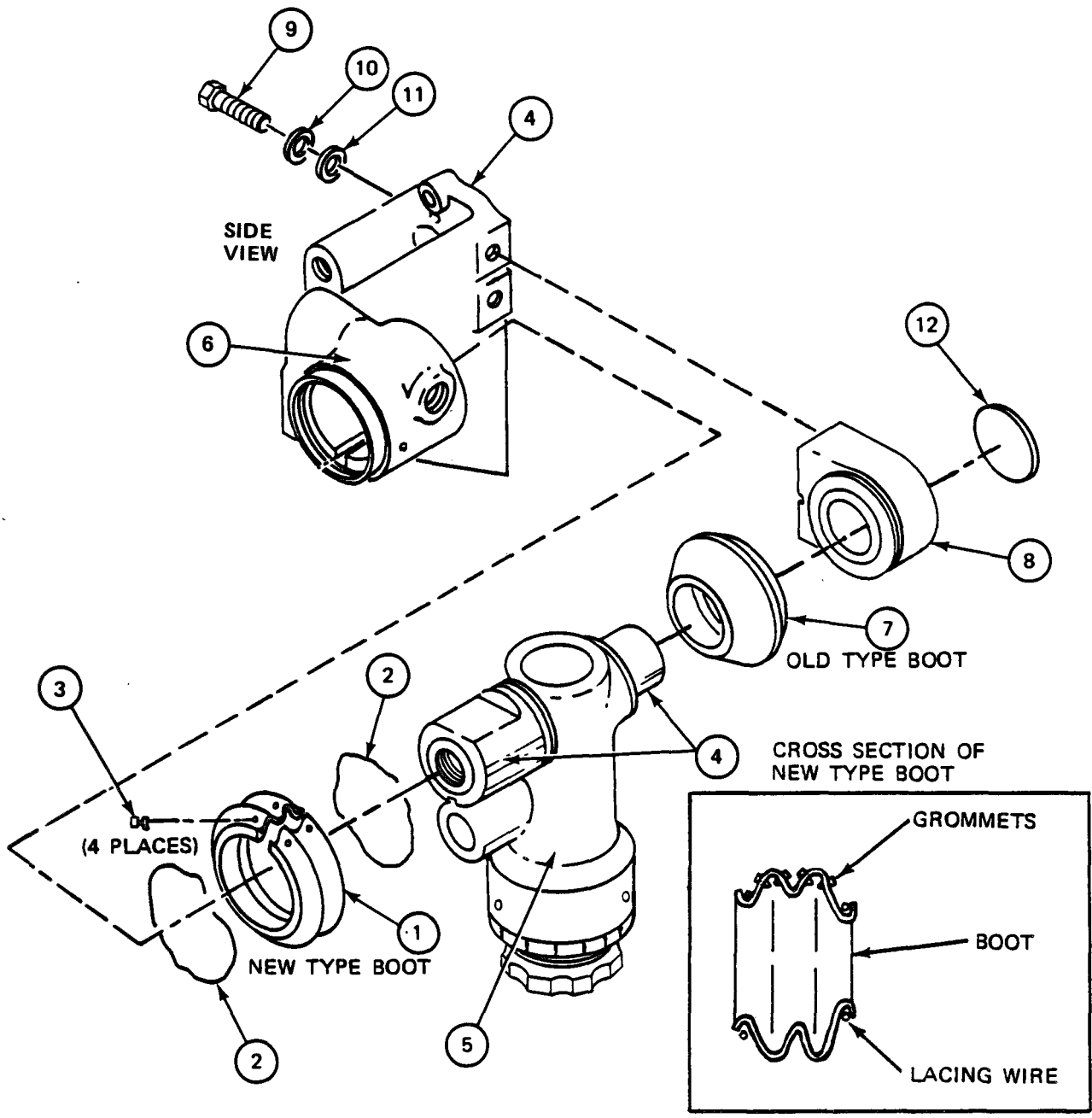

CHAPTER 5

FINAL INSPECTION

5-1. SCOPE

This chapter gives final inspection and maintenance procedures to be done after repairing the M114 Telescope Mount.

Task	Reference (para)
Backlash Check	5-2
Final Inspection	5-3

5-2. BACKLASH CHECK

TOOLS: 6 in. vise
M 105 telescope

PERSONNEL: One

REFERENCES: TM 20-2 for installing telescope (TM 9-2350 -215-20-2 for M60A1, TM 9-2350-257 -20-2 for M60A1 Rise, TM 9-2350 -260-20-2 f or M60, TM 9-2350-222-20-2 for M728, and TM 9-2350-258 -20-2 for M48A5.)

EQUIPMENT CONDITION: Telescope Mount on workbench

NOTE

A target a distance of 75 yards away will be needed for this procedure. When the telescope mount is setup in the vise with the telescope, a target 75 yards away must be able to be sighted through the telescope.

5-2. BACKLASH CHECK (CONT)

FRAME 1	
Step	Procedure
1.	Install telescope mount (1) into vise, such that there is free access to both the elevation and inflection knob assemblies.
2.	Install telescope (2) into telescope mount (1) (TM 20-2).
	NOTE The following steps are to be done for both deflection and elevation boresight knob backlash checks.
3.	Sight a target through telescope (2) that is in the midpoint of travel for boresight knob (3).
	NOTE In the following steps make sure that the directions for rotating the boresight knobs (3) in a specified direction are followed. If boresight knobs (3) are turned back and forth to sight target the check will be inaccurate.
4.	Rotate boresight knob (3) counterclockwise to lowest reading on boresight scale (4). Then rotate boresight knob (3) clockwise only and center target in telescopes reticle. Record reading on bore sight scale (4).
5.	Rotate bore sight knob (3) clockwise to highest reading on boresight scale (4). Then rotate boresight knob (3) counterclockwise only and center target in telescope's reticle. Record reading on boresight scale (4).
6.	Boresight elevation and deflection backlash should not exceed 0.1 mils. The deflection boresight knob shall provide a minimum of 20 roils movement in each direction when the deflection dial scale is in the 3 position. The elevation boresight knob shall provide a minimum of 40 roils movement in elevation when the elevation dial scale is in the 1 position. Torque requirements for rotation of the boresight knobs through full excursion shall not exceed 8 in.-lb. If criteria in lines 6, 7, and 8 is not met, replace special screw (para 4-10 for elevation knob and para 4-13 for deflection knob).
	END OF TASK

5-2. BACKLASH CHECK (CONT)

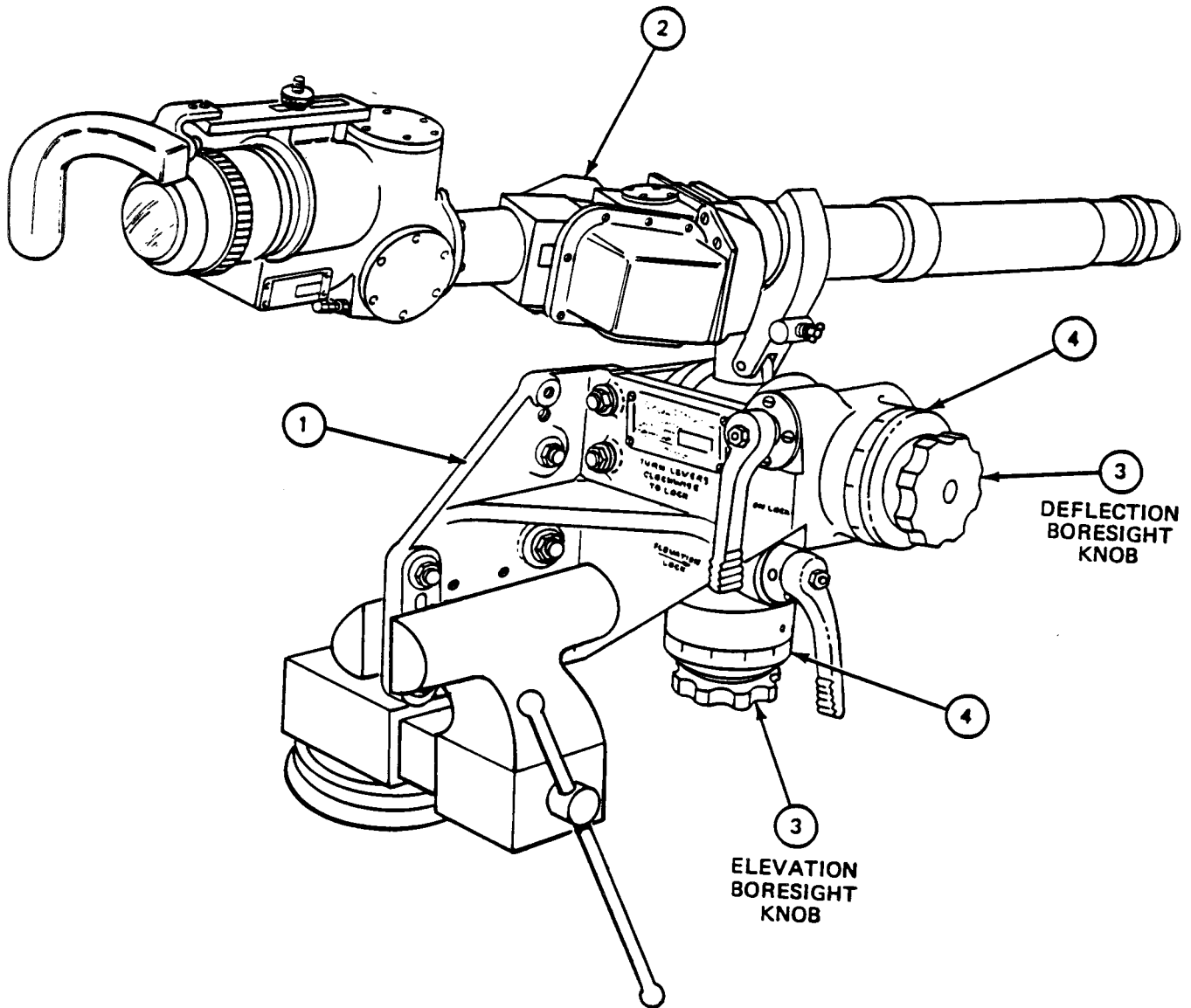

5-3. FINAL INSPECTION

PERSONNEL: One

EQUIPMENT CONDITION: Telescope mount on work bench

NOTE

If you find a fault, tell your supervisor. If you do not find a fault, install good telescope mount in tank (para 4-6).

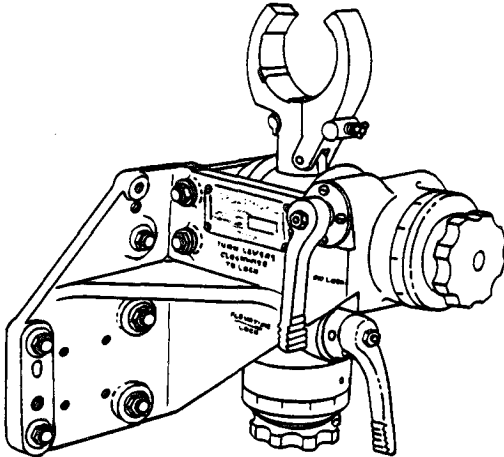
FRAME 1		
Step	Procedure	
1.	Check telescope mount (1) is complete with all screws and washers in place and ready for installing in vehicle.	
2.	Check telescope mount (1) for grease. Clean if necessary. END OF TASK	
		

CHAPTER 6

PACKAGING

6-1. SCOPE

This chapter provides information on packaging of the M114 Telescope Mount for storage or shipment.

6-2. PACKAGING OF THE M114 TELESCOPE MOUNT

Package the Telescope Mount in accordance with MIL-M-45125, TM 9-200 and TM 9-299 instructions.

APPENDIX A

EXPENDABLE/DURABLE SUPPLIES AND MATERIALS LIST

Section 1. INTRODUCTION

A-1. SCOPE

This appendix lists expendable supplies and materials you will need to repair the M114 Telescope Mount. This listing is for informational purposes only and is not authority to requisition the listed items. These items are authorized to you by CTA 50-970, Expendable/Durable Items (Except Medical, Class V, Repair Parts, and Heraldic Items), or CTA 8-100, Army Medical Department Expendable/Durable Items.

A-2. EXPLANATION OF COLUMNS

a. Column 1 - Item Number. This number is assigned to the entry in the listing and is used in the manual to identify the material, for example, sealing compound (item 6, App. A).

b. Column 2- Level. This column identifies the lowest level of maintenance that requires the listed item.

F - Direct Support Maintenance

H - General Support Maintenance

c. Column 3- National Stock Number. This is the National stock number assigned to the item. Use it to request or requisition the item.

d. Column 4- Description. This tells the Federal item name and, if needed, a description to identify the item. The last line for each item indicates the part number followed by the Federal Supply Code for Manufacturer (FSCM) in parentheses, if applicable.

e. Column 5- Unit of Measure (U/M). This column shows how the item is measured, for example, you may see these abbreviations: ea (each), in (inches), or pr (pair). Order the smallest amount you need.

Section 2. EXPENDABLE/DURABLE SUPPLIES AND MATERIALS

(1) Item No.	(2) Level	(3) National Stock No.	(4) Description	(5) U/M
1	F	5350-00-221-0872	Cloth, Abrasive: crocus, ferric oxide and quartz, Jean-cloth back, closed coating P-C-458 50 sh. sleeve	SL
2	F	9150-00-576-4262	Grease, Aircraft and Instrument: MIL-G-23827 1 lb can	LB
3	F	9150-00-273-8633	Grease, Pneumatic System: MIL-G-4343 1 qt container	QT
4	F	8010-00-298-2287	Paint, exterior surface 1 qt can	QT
5	F	8010-00-292-1127	Primer, Paint coating 1 gal. can	GL
6	F	8030-00-275-8110	Sealing Compound curing MIL-S-11031 1 kit	KT
7	F	6850-00-281-1985	Solvent, Dry Cleaning: P-D-680 4 oz can	OZ

APPENDIX B
MAINTENANCE TASK INDEX

B-1. SCOPE

This appendix helps you find maintenance tasks for the M114 Telescope Mount by giving you references to the procedures.

B-2. MAINTENANCE TASK INDEX

Para B-2
B-2

MOUNT, TELESCOPE, M114 (1240-00-676-2176)	MAINTENANCE TASKS							NOTES
	INSPECTION UPON RECEIPT (VOL II)	FINAL INSPECTION (VOL II)	CHECKOUT (VOL I)	TROUBLESHOOT (VOL I)	REMOVAL/INSTALLATION VOL II)	DISASSEMBLY/ASSEMBLY (VOL II)	TOOLS AND TEST EQUIPMENT (VOL III)	
NOMENCLATURE								
TELESCOPE MOUNT	Para 3-2	Para 5-2	Para 2-2	Vol I	Para 4-5/ 4-6		Para 2-8	
DECALS					Para 4-3			
DEFLECTION BORESIGHT ADJUSTING MECHANISM						Para 4-14/ 4-15		
DEFLECTION LOCKING MECHANISM						Para 4-8/ 4-9		
ELEVATION BORESIGHT ADJUSTING MECHANISM						Para 4-11/ 4-12		
ELEVATION LOCKING MECHANISM						Para 4-8/ 4-9		

TM 9-1240-285-34&P

B-2. MAINTENANCE TASK INDEX (CONT)

MOUNT, TELESCOPE, M114 (1240-00-676-2176)	MAINTENANCE TASKS							
	INSPECTION UPON RECEIPT (VOL II)	FINAL INSPECTION (VOL II)	CHECKOUT (VOL I)	TROUBLESHOOT (VOL I)	REMOVAL/INSTALLATION (VOL II)	DISASSEMBLY/ASSEMBLY (VOL II)	TOOLS AND TEST EQUIPMENT (VOL II)	NOTES
NOMENCLATURE								
HOLDER					Para 4-17/ 4-20	Para 4-18/ 4-19		
SLIDE ASSEMBLY AND BOOTS					Para 4-22/ 4-23			

B-3/(B-4 blank)
Para B-2 Cont

APPENDIX C
FABRICATED TOOL

C-1. SCOPE

This appendix shows the spring wrench necessary to fix the M114 Telescope Mount. Dimensions are given so that you can have the tool made.



C-2. SPRING WRENCH

Used to install spring on elevation and deflection boresight knobs.

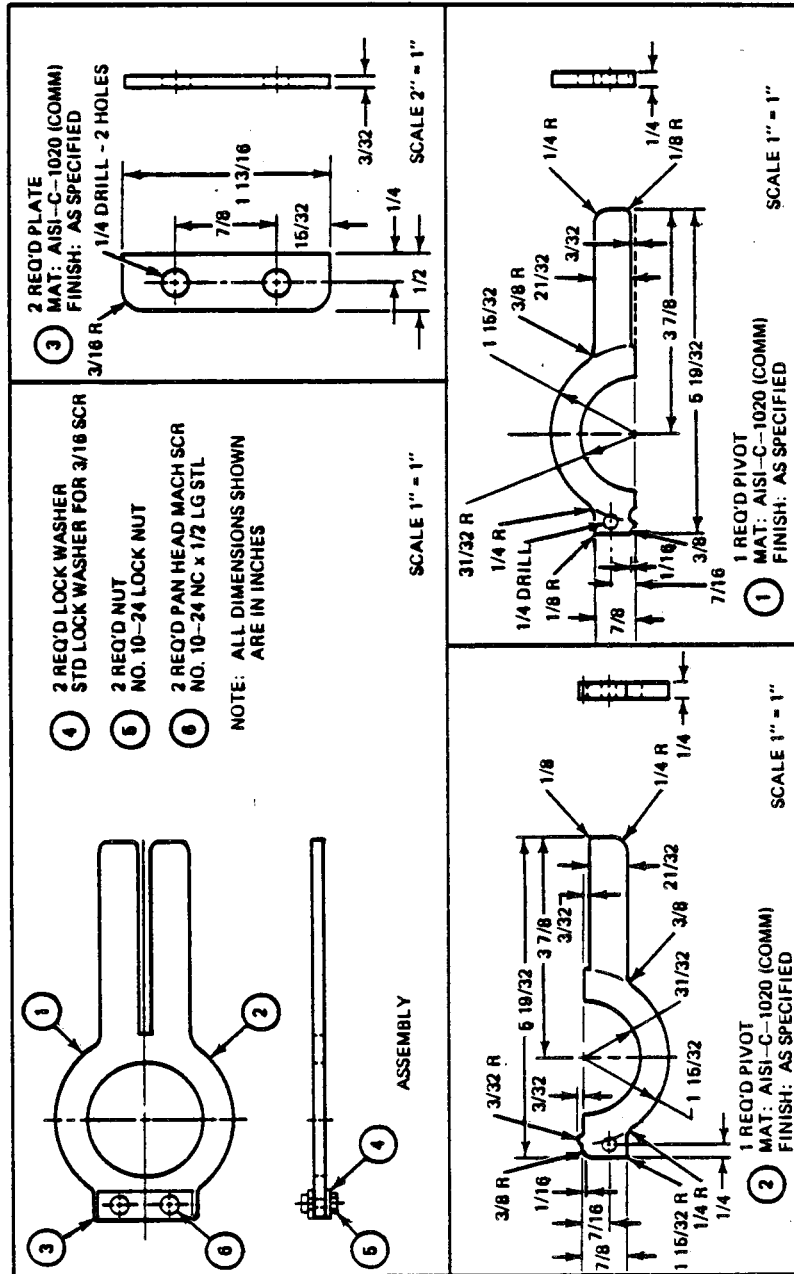

APPENDIX D
DIRECT SUPPORT AND
GENERAL SUPPORT MAINTENANCE
REPAIR PARTS AND SPECIAL TOOLS LIST

Section I. INTRODUCTION

D-1. SCOPE

This appendix lists spares and repair parts, special tools, special test, measurement, and diagnostic equipment (TMDE), and other special support equipment required for performance of direct support and general support maintenance of the Mount, Telescope, M114. It authorizes the requisitioning and issue of spares and repair parts as indicated by the source and maintenance codes.

D-2. GENERAL

This Repair Parts and Special Tools List is divided into the following sections:

a. Section II. Repair Parts List. A list of spares and repair parts authorized for use in the performance of maintenance. The list also includes parts which must be removed for replacement of the authorized parts. Parts lists are composed of functional groups in numeric sequence, with the parts in each group listed in figure and item number sequence. Bulk materials are listed in NSN sequence.

b. Section III. Special Tools List. (Not Applicable)

c. Section IV. National Stock Number and Part Number Index. A list in National item identification number (NIIN) sequence, of all National stock numbers (NSN) appearing in the listings, followed by a list in alphameric sequence of all part numbers appearing in the listings. National stock numbers and part numbers are cross-referenced to each illustration figure and item number appearance.

D-3. EXPLANATION OF COLUMNS

a. Illustration. This column is divided as follows:

(1) Figure Number. Indicates the figure number of the illustration on which the item is shown.

(2) Item Number. The number used to identify item called out in the illustration.

b. Source, Maintenance, and Recoverability (SMR) Codes.

(1) Source Code. Source codes indicate the manner of acquiring support

items for maintenance, repair, or overhaul of end items. Source codes are entered in the first and second positions of the Uniform WR Code format as follows:

Code	Definition
PA	-Item procured and stocked for anticipated or known usage.
PB	-Item procured and stocked for insurance purpose because essentiality dictates that a minimum quantity be available in the supply system.
PC	-Item procured and stocked and which otherwise would be coded PA except that it is deteriorative in nature.
PD	-Support item, excluding support equipment, procured for initial issue or outfitting and stocked only for subsequent or additional initial issues or outfitting. Not subject to automatic replenishment.
PE	-Support equipment procured and stocked for initial issue or outfitting to specified maintenance repair activities.
PF	-Support equipment which will not be stocked but which will be centrally procured on demand.
PG	-Item procured and stocked to provide for sustained support for the life of the equipment. It is applied to an item peculiar to the equipment which, because of probable discontinuance or shutdown

of production facilities, would prove uneconomical to reproduce at a later time.

KD	-An item of a depot overhaul/repair kit and not purchased separately. Depot kit defined as a kit that provides items required at the time of overhaul or repair.
KF	-An item of a maintenance kit and not purchased separately. Maintenance kit defined as a kit that provides an item that can be replaced at organizational or intermediate levels of maintenance.
KB	-Item included in both a depot overhaul/repair kit and a maintenance kit.
MO	-Item to be manufactured or fabricated at organizational level.
MF	-Item to be manufactured or fabricated at the direct support maintenance level.
MH	-Item to be manufactured or fabricated at the general support maintenance level.
MD	-Item to be manufactured or fabricated at the depot maintenance level.
AO	-Item to be assembled at organizational level.
AF	-Item to be assembled at direct support maintenance level.
AH	-Item to be assembled at general support maintenance level.

		Code	Application/Explanation
AD	-Item to be assembled at depot maintenance level.		
XA	-Item is not procured or stocked because the requirements for the item will result in the replacement of the next higher assembly.	C	-Crew or operator maintenance performed within organizational maintenance.
		O	-Support item is removed, replaced, used at the organizational level.
XB	-Item is not procured or stocked. If not available through salvage, requisition.	F	-Support item is removed, replaced, used at the direct support level.
XC	-Installation drawing, diagram, instruction sheet, field service drawing, that is identified by manufacturer's part number.	H	-Support item is removed, replaced, used at the general support level.
XD	-A support item that is not stocked. When required, item will be procured through normal supply channels.	D	-Support items that are removed, replaced, used at depot, mobile depot, or specialized repair activity only.

NOTE: Cannibalization or salvage may be used as a source of supply for any items coded above except those coded XA and aircraft support items as restricted by AR 700-42.

(2) Maintenance Code.

Maintenance codes are assigned to indicate the levels of maintenance authorized to USE and REPAIR support items. The maintenance codes are entered in the third and fourth positions of the Uniform SMR Code format as follows:

(a) The maintenance code entered in the third position will indicate the lowest maintenance level authorized to remove, replace, and use the support item. The maintenance code entered in the third position will indicate one of the following levels of maintenance:

(b) The maintenance code entered in the fourth position indicates whether the item is to be repaired and identifies the lowest maintenance level with the capability to perform complete repair (i.e., all authorized maintenance functions). This position will contain one of the following maintenance codes.

Code	Application/Explanation
O	-The lowest maintenance level capable of complete repair of the support item is the organizational level.
F	-The lowest maintenance level capable of complete repair of the support item is the direct support level.
H	-The lowest maintenance level capable of complete repair of the support item is the general support level.

- | | | | |
|---|--|---|---|
| D | -The lowest maintenance level capable of complete repair of the support item is the depot level. | D | -Reparable item. When beyond lower level repair capability, return to depot. Condemnation and disposal not authorized below depot level. |
| L | -Repair restricted to Specialized Repair Activity. (Not Applicable). | L | -Reparable item. Repair, condemnation, and disposal not authorized below depot/ specialized repair activity level. |
| Z | -Nonreparable. No repair is authorized. | | |
| B | -No repair is authorized. The item may be reconditioned by adjusting, lubricating, etc., at the user level. No parts or special tools are procured for the maintenance of this item. | A | -Item requires special handling or condemnation procedures because of specific reasons (i.e., precious metal content, high dollar value, critical material or hazardous material). Refer to appropriate manuals/directives for specific instructions. |

(3) Recoverability Code.
Recoverability codes are assigned to support items to indicate the disposition action on unserviceable items. The recoverability code is entered in the fifth position of the Uniform SMR Code format as follows:

Recover-
ability
Codes

Definition

- | | |
|---|---|
| Z | -Nonreparable item. When unserviceable, condemn and dispose at the level indicated in position 3. |
| 0 | -Reparable item. When uneconomically reparable, condemn and dispose at organizational level. |
| F | -Reparable item. When uneconomically reparable, condemn and dispose at the direct support level. |
| H | -Reparable item. When uneconomically reparable, condemn and dispose at the general support level. |

c. National Stock Number.
Indicates the National stock number assigned to the item and which will be used for requisitioning.

d. Federal Supply Code for Manufacturer (FSCM). The FSCM is a 5-digit numeric code listed in SB 708-42 which is used to identify the manufacturer, distributor, or Government agency, etc.

e. Part Number. Indicates the primary number used by the manufacturer (individual, company, firm, corporation, or Government activity), which controls the design and characteristics of the item by means of its engineering drawings, specifications, standards, and inspection requirements to identify an item or range of items.

NOTE: When a stock numbered item is requisitioned, the item received may have a different part number than the part being replaced.

f. Description. Indicates the Federal item name and, if required, a minimum description to identify the item.

g. Unit of Measure (U/M). Indicates the standard of the basic quantity of the listed item as used in performing the actual maintenance function. This measure is expressed by a two-character alphabetical abbreviation (e.g., ea, in, pr, etc). When the unit of measure differs from the unit of issue, the lowest unit of issue that will satisfy the required units of measure will be requisitioned.

h. Quantity Incorporated in Unit. Indicates the quantity of the item used in the breakout shown on the illustration figure, which is prepared for a functional group, subfunctional group, or an assembly. A "V" appearing in this column in lieu of a quantity indicates that no specific quantity is applicable, (e.g., shims, spacers, etc).

D-4. SPECIAL INFORMATION

Bulk materials required to manufacture items are listed in the Bulk Material Group of this appendix.

D-5. HOW TO LOCATE REPAIR PARTS

a. When National Stock Number or Part Number is Unknown:

(1) First. Using the table of contents, determine the functional group within which the item belongs. This is necessary since illustrations are prepared for functional groups, and listings are divided into the same groups.

(2) Second. Find the illustration covering the functional group to which the item belongs.

(3) Third. Identify the item on the illustration and note the illustration figure and item number of the item.

(4) Fourth. Using the Repair Parts Listing, find the figure and item number noted on the illustration.

b. When National Stock Number or Part Number is Known:

(1) First. Using the Index of National Stock Numbers and Part Numbers, find the pertinent National stock number or part number. This index is in NIIN sequence followed by a list of part numbers in alphameric sequence, cross-referenced to the illustration figure number and item number.

(2) Second. After finding the figure and item number, locate the figure and item number in the repair parts list.

D-6. ABBREVIATIONS

(Not Applicable)

Section II

REPAIR PARTS LIST

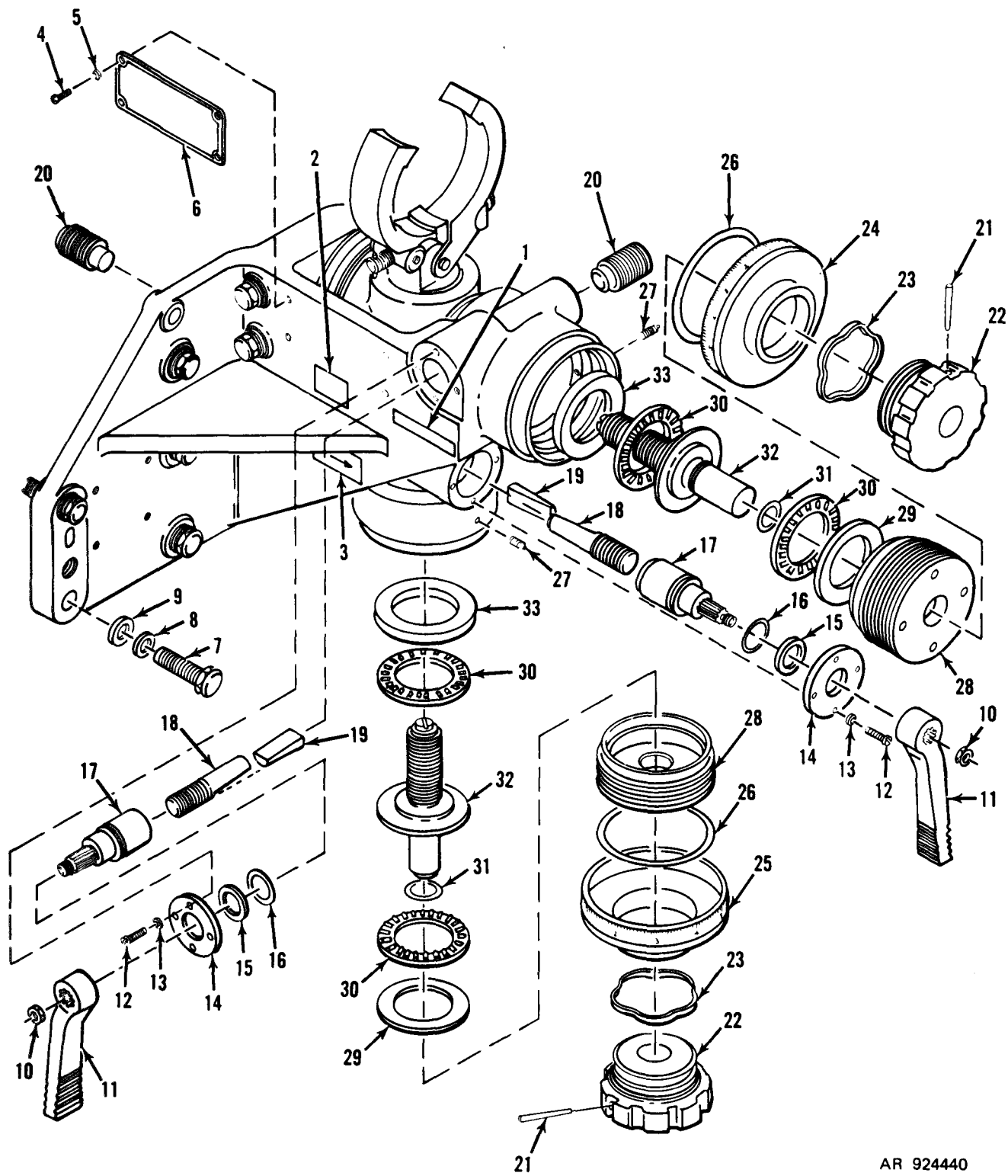

AR 924440

Figure D-1. Telescope mount M114 8574690

(1) ILLUSTRATION (a) FIG NO	(b) ITEM NO	(2) SMR CODE	(3) NATIONAL STOCK NUMBER	(4) FSCM	(5) PART NUMBER	TM9-1240-285-34&P (6) DESCRIPTION	(7) U/M	(8) QTY INC IN UNIT
						GROUP 00 TELESCOPE MOUNT M114 8574690	USABLE ON CODE	
D-1	1	PAFZZ	7690-00-753-4710	19200	8574953	DECAL	EA	1
D-1	2	PAFZZ	7690-00-405-2190	19200	8620089	DECAL	EA	1
D-1	3	PAFZZ	7690-00-656-1316	19200	8574889	DECAL	EA	1
D-1	4	PAFZZ	5305-00-059-8248	96906	MS35214-23	SCREW,MACHINE	EA	4
D-1	5	PAFZZ	5310-00-019-0669	96906	MS35333-105	WASHER, LOCK	EA	4
D-1	6	PAFZZ	9905-01-108-5506	19200	8574895	PLATE	EA	1
D-1	7	PAFZZ	5305-00-719-5221	96906	MS90727-113	SCREW,CAP,HEXAGON HEAD	EA	5
D-1	8	PAFZZ	5310-00-933-8778	96906	MS35338-143	WASHER, LOCK	EA	5
D-1	9	PAFZZ	5310-00-767-9425	96906	MS15795-818	WASHER, FLAT	EA	5
D-1	10	PAFZZ	5310-00-903-5966	96906	MS51971-1	NUT, PLAIN, HEXAGON	EA	2
D-1	11	PAFZZ	1240-00-676-2180	19200	8574932	LEVER	EA	2
D-1	12	PAFZZ	5305-00-054-6671	96906	MS51957-46	SCREW,MACHINE	EA	8
D-1	13	PAFZZ	5310-00-543-2739	96906	MS35333-72	WASHER, LOCK	EA	8
D-1	14	XDFZZ		19200	8574883	COVER	EA	2
D-1	15	PAFZZ	5310-00-655-9980	19200	8574735	WASHER, FLAT	EA	2
D-1	16	PAFZZ	5330-00-683-9572	19200	8574814	PACKING, PREFORMED	EA	3
D-1	17	PAFZZ	1240-00-445-4621	19200	8574931	SHAFT	EA	2
D-1	18	PAFZZ	1240-00-417-3018	19200	8574882	STUD, WEDGE END	EA	2
D-1	19	PAFZZ	1240-00-419-9559	19200	8574872	WEDGE, LOCKING	EA	2
D-1	20	PAFZZ	5365-00-618-8596	19200	8574871	PLUG, MACHINE	EA	2
D-1	21	PAFZZ	5315-00-187-3280	96906	MS24692-117	PIN, TAPERED, PLAIN	EA	2
D-1	22	PAFZZ	5355-00-680-8517	19200	8574937	KNOB	EA	2
D-1	23	PAFZZ	5340-00-621-7442	19200	8574779	CLIP, SPRING	EA	2
D-1	24	PAFZZ	5355-00-833-9351	19200	8574949	DIAL, SCALE	EA	1
D-1	25	PAFZZ	5355-00-691-5534	19200	8574902	DIAL, CONTROL	EA	1
D-1	26	PAFZZ	5330-00-683-9566	19200	8574835	PACKING, PREFORMED	EA	2
D-1	27	PAFZZ	5305-00-272-3533	96906	MS51023-49	SETSCREW	EA	4
D-1	28	PAFZZ	5365-00-685-0833	19200	8574938	RING, EXTERNALLY THREADED	EA	2
D-1	29	PAFZZ	5310-00-655-9985	19200	8574838	WASHER, FLAT	EA	2
D-1	30	PAFZZ	3110-00-580-3843	19200	8574860	RETAINER AND ROLLER	EA	4
D-1	31	PAFZZ	5330-00-684-2924	19200	8574780	PACKING, PREFORMED	EA	2
D-1	32	PAFZZ	5305-01-107-9160	19200	8574695	SPECIAL SCREW	EA	2
D-1	33	PAFZZ	5310-00-655-9986	19200	8574836	WASHER, FLAT	EA	2

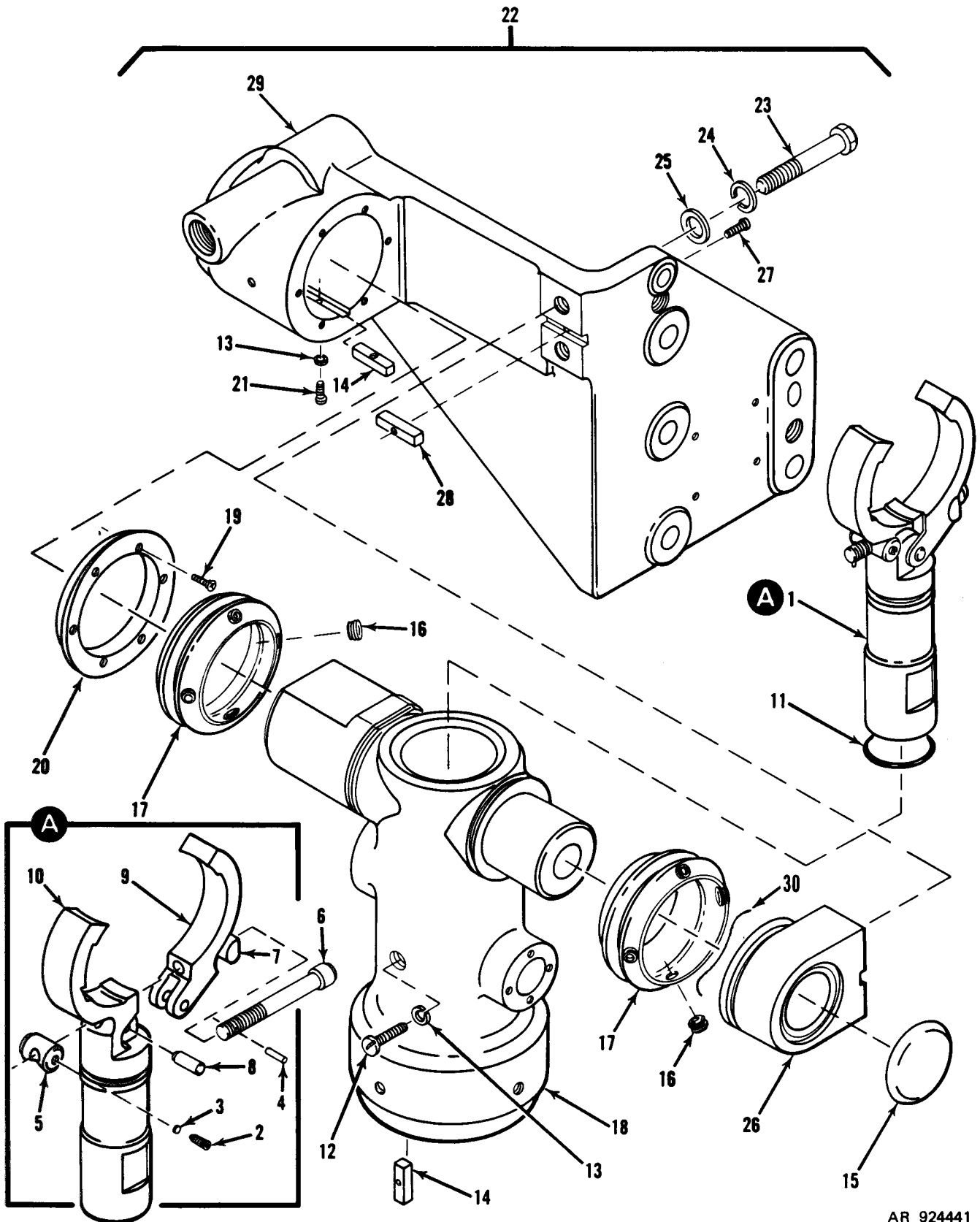

AR 924441

Figure D-2. Telescope mount M114 8574690, Holder assembly 8574694 and Housing assembly 8574691

(1) ILLUSTRATION (a) FIG NO	(b) ITEM NO	(2) SMR CODE	(3) NATIONAL STOCK NUMBER	(4) FSCM	(5) PART NUMBER	TM9-1240-285-34&P (6) DESCRIPTION	(7) U/M	(8) QTY INC IN UNIT
						GROUP 00 TELESCOPE MOUNT M114 8574690	USABLE ON CODE	
						INCLUDING		
						GROUP 0001 HOLDER ASSEMBLY 8574694 AND		
						GROUP 0002 HOUSING ASSEMBLY 8574691		
D-2	1	PAFFF	1230-01-123-6918	19200	8574694	HOLDER ASSY	EA	1
D-2	2	PAFZZ	5305-00-724-5872	96906	MS51031-58	SETSCREW	EA	1
D-2	3	PAFZZ	5340-00-685-0830	19200	8574948	DISK,SOLID,PLAIN	EA	1
D-2	4	PAFZZ	5315-00-158-5273	96906	MS51923-454	PIN,SPRING	EA	1
D-2	5	PAFZZ	5310-00-690-8287	19200	8574944	NUT,SLEEVE	EA	1
D-2	6	PAFZZ	5305-00-656-0015	19200	8574943	SCREW,CAP,SOCKET HEAD	EA	1
D-2	7	PAFZZ	1240-00-731-4979	19200	8574946	PIVOT	EA	1
D-2	8	PAFZZ	5315-00-951-3215	96906	MS16555-648	PIN,STRAIGHT	EA	1
D-2	9	PAFZZ	1240-01-107-9159	19200	8574897	CLAMP	EA	1
D-2	10	XDFZZ		19200	8574935	HOLDER	EA	1
D-2	11	PAFZZ	5330-00-683-9565	19200	8574832	PACKING,PREFORMED	EA	1
D-2	12	PAFZZ	5305-00-057-0512	96906	MS51958-15	SCREW,MACHINE	EA	1
D-2	13	PAFZZ	5310-00-193-7577	96906	MS35333-36	WASHER,LOCK	EA	2
D-2	14	PAHZZ	5315-00-685-0842	19200	8574947	KEY,MACHINE	EA	2
D-2	15	PAFZZ	5340-00-054-1412	96906	MS35648-14	PLUG,EXPANSION	EA	1
D-2	16	PAFZZ	5325-00-902-6662	19200	10516472	GROMMET BLANK	EA	8
D-2	17	PAFZZ	5975-00-762-2719	19200	10516471	BOOT,DUST AND MOISTURE SEAL	EA	2
D-2	18	XDFZZ		19200	8574693	SLIDE	EA	1
D-2	19	PAFZZ	5305-00-054-6671	96906	MS51957-46	SCREW,MACHINE	EA	6
D-2	20	PAFZZ	1240-00-676-2179	19200	8574769	RING	EA	1
D-2	21	PAFZZ	5305-00-057-0515	96906	MS51958-18	SCREW,MACHINE	EA	1
D-2	22	XDFZZ		19200	8574691	HOUSING ASSEMBLY	EA	1
D-2	23	PAFZZ	5305-00-269-3214	96906	MS90725-64	SCREW,CAP,HEXAGON HEAD	EA	2
D-2	24	PAFZZ	5310-00-637-9541	96906	MS35338-46	WASHER,LOCK	EA	2
D-2	25	PAFZZ	5310-00-773-7618	96906	MS15795-814	WASHER,FLAT	EA	2
D-2	26	XDFZZ		19200	8574692	HOUSING ASSY	EA	1
D-2	27	PAFZZ	5305-00-978-9344	96906	MS16997-12	SCREW,CAP,SOCKET HEAD	EA	1
D-2	28	PAFZZ	5315-00-685-0840	19200	8574738	KEY,MACHINE	EA	1
D-2	29	XAFZZ		19200	8574939	HOUSING	EA	1
D-2	30	MFFZZ		96906	MS9226-04	WIRE,NONELECTRICAL (MFD FROM 9505-00-995-3177)	EA	1

(1) ILLUSTRATION (a) FIG NO	(2) (b) ITEM NO	(3) SMR CODE	(4) NATIONAL STOCK NUMBER	(5) FSCM	(6) PART NUMBER	TM9-1240-285-34&P DESCRIPTION	(7) USABLE ON CODE	(8) QTY INC IN UNIT
BULK	PAFZZ	9505-00-995-3177	96906	MS9226-04	GROUP 99 BULK MATERIALS LIST WIRE, NONELECTRICAL		LB	1

Section III

SPECIAL TOOLS LIST

(NOT APPLICABLE)

Section IV

NATIONAL STOCK NUMBER AND PART NUMBER INDEX

NATIONAL STOCK NUMBER AND PART NUMBER INDEX

STOCK NUMBER	FIGURE NO.	ITEM NO.	STOCK NUMBER	FIGURE NO.	ITEM NO.
5310-00-019-0669	D-1	5	5330-00-683-9565	D-2	11
5340-00-054-1412	D-2	15	5330-00-683-9566	D-1	26
5305-00-054-6671	D-1	12	5330-00-683-9572	D-1	16
5305-00-054-6671	D-2	19	5330-00-684-2924	D-1	31
5305-00-057-0512	D-2	12	5340-00-685-0830	D-2	3
5305-00-057-0515	D-2	21	5365-00-685-0833	D-1	28
5305-00-059-8248	D-1	4	5315-00-685-0840	D-2	28
5315-00-158-5273	D-2	4	5315-00-685-0842	D-2	14
5315-00-187-3280	D-1	21	5310-00-690-8287	D-2	5
5310-00-193-7577	D-2	13	5355-00-691-5534	D-1	25
5305-00-269-3214	D-2	23	5305-00-719-5221	D-1	7
5305-00-272-3533	D-1	27	5305-00-724-5872	D-2	2
7690-00-405-2190	D-1	2	1240-00-731-4979	D-2	7
1240-00-417-3018	D-1	18	7690-00-753-4710	D-1	1
1240-00-419-9559	D-1	19	5975-00-762-2719	D-2	17
1240-00-445-4621	D-1	17	5310-00-767-9425	D-1	9
5310-00-543-2739	D-1	13	5310-00-773-7618	D-2	25
3110-00-580-3843	D-1	30	5355-00-833-9351	D-1	24
5365-00-618-8596	D-1	20	5325-00-902-6662	D-2	16
5340-00-621-7442	D-1	23	5310-00-903-5966	D-1	10
5310-00-637-9541	D-2	24	5310-00-933-8778	D-1	8
5310-00-655-9980	D-1	15	5315-00-951-3215	D-2	8
5310-00-655-9985	D-1	29	5305-00-978-9344	D-2	27
5310-00-655-9986	D-1	33	9505-00-995-3177	BULK	
5305-00-656-0015	D-2	6	1240-01-107-9159	D-2	9
7690-00-656-1316	D-1	3	5305-01-107-9160	D-1	32
1240-00-676-2179	D-2	20	9905-01-108-5506	D-1	6
1240-00-676-2180	D-1	11	1230-01-123-6918	D-2	1
5355-00-680-8517	D-1	22			

FSCM	PART NUMBER	FIGURE NO.	ITEM NO.	FSCM	PART NUMBER	FIGURE NO.	ITEM NO.
96906	MS15795-814	D-2	25	19200	8574738	D-2	
96906	MS15795-818	D-1	9	19200	8574769	D-2	20
96906	MS16555-648	D-2	8	19200	8574779	D-1	23
96906	MS16997-12	D-2	27	19200	8574780	D-1	31
96906	MS24692-117	D-1	21	19200	8574814	D-1	16
96906	MS35214-23	D-1	4	19200	8574832	D-2	11
96906	MS35333-105	D-1	5	19200	8574835	D-1	26
96906	MS35333-36	D-2	13	19200	8574836	D-1	33
96906	MS35333-72	D-1	13	19200	8574838	D-1	29
96906	MS35338-143	D-1	8	19200	8574860	D-1	30
96906	MS35338-46	D-2	24	19200	8574871	D1	20
96906	MS35648-14	D-2	15	19200	8574872	D-1	19
96906	MS51023-49	D-1	27	19200	8574882	D-1	18
96906	MS51031-58	D-2	2	19200	8574883	D-1	14
96906	MS51923-454	D-2	4	19200	8574889	D-1	3
96906	MS51957-46	D-1	12	19200	8574895	D-1	6
96906	MS51957-46	D-2	19	19200	8574897	D-2	9
96906	MS51958-15	D-2	12	19200	8574902	D-1	25
96906	MS51958-18	D-2	21	19200	8574931	D-1	17
96906	MS51971-1	D-1	10	19200	8574932	D-1	11
96906	MS90725-64	D-2	23	19200	8574935	D-2	10
96906	MS90727-113	D-1	7	19200	8574937	D-1	22
96906	MS9226-04	D-2	30	19200	8574938	D-1	28
96906	MS9226-04	BULK		19200	8574939	D-2	29
19200	10516471	D-2	17	19200	8574943	D-2	6
19200	10516472	D-2	16	19200	8574944	D-2	5
19200	8574691	D-2	22	19200	8574946	D-2	7
19200	8574692	D-2	26	19200	8574947	D-2	14
19200	8574693	D-2	18	19200	8574948	D-2	3
19200	8574694	D-2	1	19200	8574949	D-1	24
19200	8574695	D-1	32	19200	8574953	D-1	1
19200	8574735	D-1	15	19200	8620089	D-1	2

By Order of the Secretary of the Army:

JOHN A. WICKHAM, JR.
General, United States Army
Chief of Staff

Official:

DONALD J. DELANDRO
Brigadier General, United States Army
The Adjutant General

DISTRIBUTION:

To be distributed in accordance with DA Form 12-37, Direct and General Support Maintenance requirements for Tanks, Combat, Full Tracked, 105mm, M60; 105m, M60A1; Miscellaneous Combat Vehicle, Combat Engineer, Full Track, M728; Tank, Combat Full Tracked, 105mm, M60A1 (RISE) and Tank Combat, Full Tracked, 105mm, M48A5.



THEN... JOT DOWN THE DOPE ABOUT IT ON THIS FORM, TEAR IT OUT, FOLD IT AND DROP IT IN THE MAIL!

SOMETHING WRONG WITH THIS MANUAL?

FROM: (YOUR UNIT'S COMPLETE ADDRESS)

Your mailing address.

DATE Date you fill out this form.

PUBLICATION NUMBER

TM 9-XXXX-XXX-XX

DATE

Date of TM

TITLE

Title of TM

BE EXACT... PIN-POINT WHERE IT IS

IN THIS SPACE TELL WHAT IS WRONG AND WHAT SHOULD BE DONE ABOUT IT:

PAGE NO.	PARA-GRAPH	FIGURE NO.	TABLE NO.
3		2	
109		51	
2-8			2-1
12	1-6a		

Item 10. Change illustration. Reason: Tube end shown assembled on wrong side of lever cam.

Item 3. The NSN and P/N are not listed on the AMDF nor the MCRL. Request correct NSN and P/N be furnished.

Preventive Maintenance Checks and Services. Item 7 under "Items to be inspected" should be changed to read as follows: Firing linkage and firing mechanism pawl.

Since there are both 20- and 30- round magazines for this rifle, data on both should be listed.

SAMPLE

TYPED NAME, GRADE OR TITLE, AND TELEPHONE NUMBER

SIGN HERE:

TEAR ALONG DOTTED LINE

RECOMMENDED CHANGES TO EQUIPMENT TECHNICAL PUBLICATIONS



THEN... JOT DOWN THE DOPE ABOUT IT ON THIS FORM, CAREFULLY TEAR IT OUT, FOLD IT AND DROP IT IN THE MAIL!

SOMETHING WRONG WITH THIS PUBLICATION?

FROM: (PRINT YOUR UNIT'S COMPLETE ADDRESS)

DATE SENT

PUBLICATION NUMBER

TM 9-1240-285-34&P

PUBLICATION DATE

2 May 1985

PUBLICATION TITLE

MOUNT, TELESCOPE, M114

BE EXACT... PIN-POINT WHERE IT IS

PAGE NO.

PARA-GRAPH

FIGURE NO.

TABLE NO.

IN THIS SPACE TELL WHAT IS WRONG AND WHAT SHOULD BE DONE ABOUT IT:

PRINTED NAME, GRADE OR TITLE, AND TELEPHONE NUMBER

SIGN HERE:

FILL IN YOUR
UNIT'S ADDRESS

FOLD BACK

TEAR ALONG PERFORATED LINE

DEPARTMENT OF THE ARMY

OFFICIAL BUSINESS
PENALTY FOR PRIVATE USE \$300

POSTAGE AND FEES PAID
DEPARTMENT OF THE ARMY
DOD 314



Commander
US Army Armament, Munitions and Chemical Command
ATTN: AMSMC-MAS
Rock Island, IL 61201-9990

THE METRIC SYSTEM AND EQUIVALENTS

LINEAR MEASURE

1 Centimeter = 10 Millimeters = 0.01 Meters = 0.3937 Inches
 1 Meter = 100 Centimeters = 1000 Millimeters = 39.37 Inches
 1 Kilometer = 1000 Meters = 0.621 Miles

SQUARE MEASURE

1 Sq Centimeter = 100 Sq Millimeters = 0.155 Sq Inches
 1 Sq Meter = 10,000 Sq Centimeters = 10.76 Sq Feet
 1 Sq Kilometer = 1,000,000 Sq Meters = 0.386 Sq Miles

WEIGHTS

1 Gram = 0.001 Kilograms = 1000 Milligrams = 0.035 Ounces
 1 Kilogram = 1000 Grams = 2.2 Lb
 1 Metric Ton = 1000 Kilograms = 1 Megagram = 1.1 Short Tons

CUBIC MEASURE

1 Cu Centimeter = 1000 Cu Millimeters = 0.06 Cu Inches
 1 Cu Meter = 1,000,000 Cu Centimeters = 35.31 Cu Feet

LIQUID MEASURE

1 Milliliter = 0.001 Liters = 0.0338 Fluid Ounces
 1 Liter = 1000 Milliliters = 33.82 Fluid Ounces

TEMPERATURE

$5/9 (^{\circ}\text{F} - 32) = ^{\circ}\text{C}$
 212^o Fahrenheit is equivalent to 100^o Celsius
 90^o Fahrenheit is equivalent to 32.2^o Celsius
 32^o Fahrenheit is equivalent to 0^o Celsius
 $9/5 \text{ C}^{\circ} + 32 = \text{F}^{\circ}$

APPROXIMATE CONVERSION FACTORS

<u>TO CHANGE</u>	<u>TO</u>	<u>MULTIPLY BY</u>
Inches	Centimeters	2.540
Feet	Meters	0.305
Yards	Meters	0.914
Miles	Kilometers	1.609
Square Inches	Square Centimeters	6.451
Square Feet	Square Meters	0.093
Square Yards	Square Meters	0.836
Square Miles	Square Kilometers	2.590
Acres	Square Hectometers	0.405
Cubic Feet	Cubic Meters	0.028
Cubic Yards	Cubic Meters	0.765
Fluid Ounces	Milliliters	29.573
Pints	Liters	0.473
Quarts	Liters	0.946
Gallons	Liters	3.785
Ounces	Grams	28.349
Pounds	Kilograms	0.454
Short Tons	Metric Tons	0.907
Pound-Feet	Newton-Meters	1.356
Pounds per Square Inch	Kilopascals	6.895
Miles per Gallon	Kilometers per Liter	0.425
Miles per Hour	Kilometers per Hour	1.609

<u>TO CHANGE</u>	<u>TO</u>	<u>MULTIPLY BY</u>
Centimeters	Inches	0.394
Meters	Feet	3.280
Meters	Yards	1.094
Kilometers	Miles	0.621
Square Centimeters	Square Inches	0.155
Square Meters	Square Feet	10.764
Square Meters	Square Yards	1.196
Square Kilometers	Square Miles	0.386
Square Hectometers	Acres	2.471
Cubic Meters	Cubic Feet	35.315
Cubic Meters	Cubic Yards	1.308
Milliliters	Fluid Ounces	0.034
Liters	Pints	2.113
Liters	Quarts	1.057
Liters	Gallons	0.264
Grams	Ounces	0.035
Kilograms	Pounds	2.205
Metric Tons	Short Tons	1.102
Newton-Meters	Pound-Feet	0.738
Kilopascals	Pounds per Square Inch	0.145
Kilometers per Liter	Miles per Gallon	2.354
Kilometers per Hour	Miles per Hour	0.621

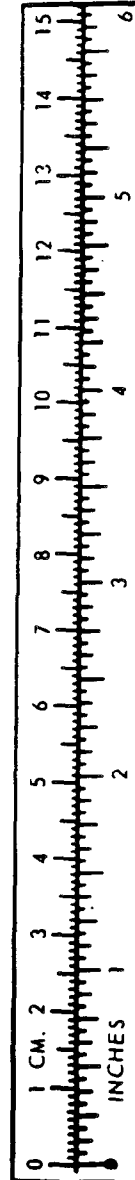

PIN: 057972-001